



Southwest Ranches Town Council

REGULAR MEETING

Agenda of February 28, 2019

Southwest Ranches Council Chambers
7:00 PM Thursday

13400 Griffin Road
Southwest Ranches, FL 33330

<u>Mayor</u> Doug McKay	<u>Town Council</u> Freddy Fisikelli Bob Hartmann	<u>Town Administrator</u> Andrew D. Berns	<u>Town Attorney</u> Keith M. Poliakoff, J.D.
<u>Vice Mayor</u> Gary Jablonski	Denise Schroeder	<u>Town Financial Administrator</u> Martin Sherwood, CPA CGFO	<u>Assistant Town Administrator/Town Clerk</u> Russell C. Muniz, MMC

In accordance with the Americans with Disabilities Act of 1990, persons needing special accommodation, a sign language interpreter or hearing impaired to participate in this proceeding should contact the Town Clerk at (954) 434-0008 for assistance no later than four days prior to the meeting.

1. Call to Order/Roll Call

2. Pledge of Allegiance

3. Public Comment

- All Speakers are limited to 3 minutes.
- Public Comment will last for 30 minutes.
- All comments must be on non-agenda items.
- All Speakers must fill out a request card prior to speaking.
- All Speakers must state first name, last name, and mailing address.
- Speakers will be called in the order the request cards were received.
- Request cards will only be received until the first five minutes of public comment have concluded.

4. Board Reports

5. Council Member Comments

6. Legal Comments

7. Administration Comments

8. A RESOLUTION OF THE TOWN COUNCIL OF THE TOWN OF SOUTHWEST RANCHES, FLORIDA, APPROVING AN AGREEMENT IN THE AMOUNT OF FIFTY-NINE THOUSAND THREE HUNDRED TWENTY-FOUR DOLLARS AND NINETY CENTS (\$59,324.90) WITH PHI CONSTRUCTION, INC. TO CONSTRUCT IMPROVEMENTS IN THE FRONTIER TRAILS CONSERVATION AREA; AUTHORIZING THE MAYOR, TOWN ADMINISTRATOR, AND TOWN ATTORNEY TO ENTER INTO AN AGREEMENT; APPROVING A BUDGET AMENDMENT TO THE FISCAL YEAR 2018/2019 BUDGET FOR THE FRONTIER TRAILS PARK IMPROVEMENT; AND PROVIDING AN EFFECTIVE DATE.

Discussion

9. Annual Review of Charter Officials

{Tabled from January 24, 2019}

10. Proposed FY 2019-2020 Budget Calendar

11. Approval of Minutes

a. November 15, 2018 Regular Meeting

b. January 24, 2019 Regular Meeting

12. Adjournment

PURSUANT TO FLORIDA STATUTES 286.0105, THE TOWN HEREBY ADVISES THE PUBLIC THAT IF A PERSON DECIDES TO APPEAL ANY DECISION MADE BY THIS COUNCIL WITH RESPECT TO ANY MATTER CONSIDERED AT ITS MEETING OR HEARING, HE OR SHE WILL NEED A RECORD OF THE PROCEEDINGS, AND THAT FOR SUCH PURPOSE, THE AFFECTED PERSON MAY NEED TO ENSURE THAT A VERBATIM RECORD OF THE PROCEEDING IS MADE, WHICH RECORD INCLUDES THE TESTIMONY AND EVIDENCE UPON WHICH THE APPEAL IS TO BE BASED. THIS NOTICE DOES NOT CONSTITUTE CONSENT BY THE TOWN FOR THE INTRODUCTION OR ADMISSION OF OTHERWISE INADMISSIBLE OR IRRELEVANT EVIDENCE, NOR DOES IT AUTHORIZE CHALLENGES OR APPEALS NOT OTHERWISE ALLOWED BY LAW.



Town of Southwest Ranches
13400 Griffin Road
Southwest Ranches, FL 33330-2628

(954) 434-0008 Town Hall
(954) 434-1490 Fax

Town Council
Doug McKay, Mayor
Gary Jablonski, Vice Mayor
Freddy Fisikelli, Council Member
Bob Hartmann, Council Member
Denise Schroeder, Council Member

Andrew D. Berns, Town Administrator
Keith M. Poliakoff, JD, Town Attorney
Russell Muniz, Assistant Town Administrator/Town Clerk
Martin D. Sherwood, CPA, CGMA, CGFO, Town Financial Administrator

COUNCIL MEMORANDUM

TO: Honorable Mayor McKay and Town Council
VIA: Andrew D. Berns, Town Administrator
FROM: Rod Ley, P.E., Town Engineer
DATE: 1/24/2019
SUBJECT: Approving an Agreement with PHI Construction, Inc. for the Frontier Trails Conservation Area Improvements

Recommendation

To place this item on the agenda for Council consideration and approval of an agreement with PHI Construction, Inc. for the Frontier Trails Conservation Area parking and pavilion. The Recreation, Forestry, and Natural Resources Advisory Board recommended and prioritized this project for Fiscal Year 2018-2019.

Unanimous Vote of the Town Council Required?

No

Strategic Priorities

- A. Sound Governance
- B. Enhanced Resource Management
- E. Cultivate a Vibrant Community

Background

Frontier Trails Conservation Area is located at the intersection of SW 193rd Lane and SW 51st Manor in Southwest Ranches. The Town acquired the 30-acre Frontier Trails Conservation Area with grants from Broward County and Florida Communities Trust. The park remains the priority for development by the Recreation, Forestry, and Natural Resources Advisory Board. The Town agreed to grant commitments to develop this park including

parking and picnic facilities.

On November 7, 2018 the Town advertised IFB 19-001. The project includes, but is not limited, to the construction of a grass drive, a one grass parking space, one handicap space, an ADA accessible sidewalk and installation of a prefab Poligon pavilion (Shelter Model: SQR12TGSS) on a concrete slab, installation of grass sod, tree protection, all related earthwork, striping, grading and drainage and associated erosion control measures.

On December 11, 2018, the Town received seven (7) responses:

Proposer	Total Lump Sum (ranked lowest to highest)
PHI Construction	\$59,324.90
IMF Estimating & Corp	\$66,126.06
Bejar Construction, Inc.	\$72,279.90
Sagaris Corp	\$73,053.90
Florida Blacktop, Inc.	\$73,396.70
Close Construction, LLC	\$89,089.90
V Engineering and Consulting Corp	\$98,843.90

After reviewing the bids, it was determined that PHI Construction, Inc. was the lowest responsive and responsible bidder that met the requirement of the IFB. As per the contract, substantial completion will be 150 calendar days after the issuance of the Notice to Proceed (NTP), and final completion will be 180 calendar days after the NTP. However, Staff is targeting final completion on or before current fiscal year end (September 30, 2019).

Fiscal Impact/Analysis

Fifty Thousand Dollars (\$50,000) was available for improvements in Account # 301-5300-572-63220 during FY 2018 of which \$40,410 was unspent and available for construction in subsequent years. Additionally, the Town budgeted \$75,000 for further improvements to Frontier Trails Park in FY 2019 of which \$18,915 (\$59,325 construction – 40,410 carry over) will be utilized for this construction phase of Frontier Trails Park.

A budget amendment for the Frontier Trails Park Improvements is needed as follows: increasing Capital Projects Fund- Infrastructure-Frontier Trails Park expenditure account (301-5300-572-63220) in the amount of \$40,410.00. Regarding the additional revenue required, Capital Projects-Assigned Fund Balance (reserves) will need to be utilized in the amount of \$20,000 and the remaining Capital Projects Restricted Fund Balance will be utilized for the balance of the Aster Knight Parks Foundation Grant from FY 2018 in the amount of \$20,410.

Revenue Accounts:

301-0000-399-39900 \$40,410 (Appropriated Fund Balance – Governmental)
Total \$40,410

Expenditure Accounts:

301-5300-572-63220 \$40,410 (Capital Projects Fund
Infrastructure-Frontier Trails Park)
Total \$40,410

Staff Contact:

Philip Chorath, EI, Engineer I
Rod Ley, PE, LEED AP, CPESC, Town Engineer
Emily Aceti, Community Services Manager
December Lauretano Haines, Parks, Recreation, Open Space Manager
Martin Sherwood, Town Financial Administrator
Mara Semper, Procurement and Budget Officer

ATTACHMENTS:

Description	Upload Date	Type
Frontier Trails Agreement with PHI Reso - TA Approved	1/17/2019	Resolution
Agreement	1/4/2019	Agreement
Exhibit - Plans	1/17/2019	Exhibit
Exhibit - PHI Bid Schedule	1/7/2019	Exhibit

RESOLUTION NO. 2019-XXX

A RESOLUTION OF THE TOWN COUNCIL OF THE TOWN OF SOUTHWEST RANCHES, FLORIDA, APPROVING AN AGREEMENT IN THE AMOUNT OF FIFTY-NINE THOUSAND THREE HUNDRED TWENTY-FOUR DOLLARS AND NINETY CENTS (\$59,324.90) WITH PHI CONSTRUCTION, INC. TO CONSTRUCT IMPROVEMENTS IN THE FRONTIER TRAILS CONSERVATION AREA; AUTHORIZING THE MAYOR, TOWN ADMINISTRATOR, AND TOWN ATTORNEY TO ENTER INTO AN AGREEMENT; APPROVING A BUDGET AMENDMENT TO THE FISCAL YEAR 2018/2019 BUDGET FOR THE FRONTIER TRAILS PARK IMPROVEMENT; AND PROVIDING AN EFFECTIVE DATE.

WHEREAS, the Town desires to begin development of the Frontier Trails Conservation Area; and

WHEREAS, the Town's Recreation, Forestry, and Natural Resources Advisory Board ranked and prioritized this park for development in fiscal year's 2018 and 2019; and

WHEREAS, on November 7, 2018, the Town advertised Invitation for Bid (IFB) 19-001 for the Frontier Trails Conservation Area pavilion, parking spaces, sidewalk, and landscaping; and

WHEREAS, on December 11, 2018, the Town received seven (7) responses; and

WHEREAS, after reviewing the bids, it was determined that PHI Construction, Inc. was the lowest responsive and responsible bidder that met the requirement of the IFB; and

WHEREAS, PHI Construction, Inc's bid tabulation, as the lowest responsive and responsible bidder, came in at Fifty-Nine Thousand Three Hundred Twenty-Four Dollars and Ninety Cents (\$59,324.90); and

WHEREAS, the Aster Knight Parks Foundation originally donated Thirty Thousand Dollars and Zero Cents (\$30,000.00) for the development of this conservation area during FY 2018 of which Twenty Thousand Four Hundred and Ten Dollars and Zero Cents (\$20,410.00) is available; and

WHEREAS, Fifty Thousand Dollars and Zero Cents (\$50,000.00) was available for improvements in Account # 301-5300-572-63220 during FY 2018 of which Forty

Thousand Four Hundred Ten Dollars and Zero Cents (\$40,410.00) was unspent and available for construction in subsequent years; and

WHEREAS, the Town budgeted Seventy-Five Thousand Dollars and Zero Cents (\$75,000.00) for further improvements to Frontier Trails Conservation Area in FY 2019 of which Eighteen Thousand Nine Hundred Fifteen Dollars and Zero Cents (\$18,915.00) (\$59,325.00 construction – 40,410.00 carry over) is needed and will be utilized for this construction phase of Frontier Trails Park; and

WHEREAS, the project includes, but is not limited to, the furnishing of all labor, materials, tools, equipment, machinery, expertise, services, and all else necessary for proper construction and completion of the project; and

WHEREAS, the Town of Southwest Ranches desires to enter into an Agreement under the terms and conditions set forth hereinafter.

NOW, THEREFORE, BE IT RESOLVED BY THE TOWN COUNCIL OF THE TOWN OF SOUTHWEST RANCHES, FLORIDA:

Section 1. The above-referenced recitals are true and correct and are incorporated herein by reference.

Section 2. The Town Council hereby approves an Agreement in the amount of Fifty-Nine Thousand Three Hundred Twenty-Four Dollars and Ninety Cents (\$59,324.90) with PHI Construction, Inc. to complete the Frontier Trails Conservation Area Project, in accordance with the terms and conditions contained within the procurement and the Agreement attached hereto as Exhibit "A", which is incorporated herein by reference.

Section 3. The Town Council hereby authorizes the Mayor, Town Administrator, and Town Attorney, to enter into an Agreement in substantially the same form as that attached hereto as Exhibit "A", and to make such modifications, additions, and/or deletions which they deem necessary and proper to effectuate the intent of this Resolution.

Section 4. The Town Council hereby approves the necessary budget amendment for the Frontier Trails Conservation Area Improvements as follows: increasing Capital Projects Fund- Infrastructure-Frontier Trails Park expenditure account (301-5300-572-63220) in the amount of Forty Thousand Four Hundred Ten Dollars and Zero Cents (\$40,410). Regarding the additional revenue required, Capital Projects-Assigned Fund Balance (reserves) will need to be utilized in the amount of Twenty Thousand Dollars and Zero Cents (\$20,000.00) and the remaining Capital Projects Restricted Fund Balance will be utilized for the balance of the Aster Knight Parks Foundation Grant from FY 2018 in the amount of Twenty Thousand Four Hundred Ten Dollars and Zero Cents (\$20,410.00).

Revenue Accounts:
 301-0000-399-39900 \$40,410.00 (Appropriated Fund Balance –
 Governmental)
Total \$40,410.00

Expenditure Accounts:
 301-5300-572-63220 \$40,410.00 (Capital Projects Fund Infrastructure-
 Frontier Trails Park)
Total \$40,410.00

Section 5. That this Resolution shall become effective immediately upon its adoption.

PASSED AND ADOPTED by the Town Council of the Town of Southwest Ranches, Florida, this 24th day of January, 2019 on a motion by _____ and seconded by _____.

McKay _____
 Jablonski _____
 Fisikelli _____
 Hartmann _____
 Schroeder _____

Ayes _____
 Nays _____
 Absent _____
 Abstaining _____

 Doug McKay, Mayor

Attest:

 Russell Muñiz, Assistant Town Administrator/Town Clerk

Approved as to Form and Correctness:

 Keith Poliakoff, Town Attorney



EXHIBIT "A"

AGREEMENT

BETWEEN THE

TOWN OF SOUTHWEST RANCHES

AND

P.H.I. CONSTRUCTION, INC.

FOR

FRONTIER TRAILS PARK

IFB No. 19-001

AGREEMENT FOR
FRONTIER TRAILS PARK

THIS IS AN AGREEMENT (“Agreement” or “Contract”) made and entered into on this 24th day of January 2019 by and between the Town of Southwest Ranches, a Municipal Corporation of the State of Florida, (hereinafter referred to as “Town”) and P.H.I. Construction, Inc. (hereinafter referred to as “Contractor”).

WHEREAS, the Town desires to begin development of Frontier Trails Conservation Area (“Project”); and

WHEREAS, the Town advertised an Invitation for Bids, IFB No. 19-001 on November 7, 2018 (“IFB”); and

WHEREAS, seven (7) bids were received by the Town on December 11, 2018; and

WHEREAS, the Town has adopted Resolution No. 201_ - ____ at a public meeting of the Town Council approving the recommended award and has selected P.H.I. Construction, Inc. for award of the Project.

NOW THEREFORE, in consideration of the foregoing premises and the mutual terms and conditions herein, the Town and Contractor hereby agree as follows:

Section 1: Scope of Services

- 1.1 Upon execution of this Agreement, the Contractor agrees to perform the duties and responsibilities as defined herein and in the IFB to which this Agreement is EXHIBIT “A” and which is made a part hereof by this reference (hereinafter referred to as “Work”). This Agreement, as well as all Exhibits, the IFB, the Contractor’s Bid, including all forms attached thereto, and all addenda, specifications, drawings and plans, shall be hereinafter collectively referred to as the “Contract Documents” and incorporated herein by reference. To the extent of any conflict among the Contract Documents, the more stringent criteria relative to the Contractor’s performance of the Work shall govern over the less stringent criteria.
- 1.2 All Work rendered pursuant to this Agreement by Contractor shall be performed in accordance with the applicable standard of care for persons or entities performing similar work in Broward County, Florida. Contractor shall perform the Work in strict accordance with the requirements of this Agreement, all of the other Contract Documents, good construction practices for this type of Work performed in Broward County, Florida and all applicable codes, ordinances, rules, laws and regulations governing the Work, including, but not limited to, the Florida Building Code, along with Broward County Amendments to it.
- 1.3 By submitting its Bid and entering into this Agreement, Contractor represents that it has visited the location of the Work and informed itself of the conditions that exist at the site, including conditions of the facilities and difficulties attending the execution of the Work and such existing site conditions have been accounted for within the Contract Price (as defined below). Furthermore, all costs for the

proper disposal of excess material generated on site in the performance of the Work have likewise been included and accounted for within the Contract Price (as defined below).

- 1.4 Contractor, in addition to any manufacturer's warranty for materials or equipment, hereby warrants that its work will be free of defects and deficiencies for a period of one year(s) from the Final Completion Date (as defined below). If any defects or deficiencies arise within the warranty period, the Contractor shall correct the defect or deficiency at no cost to the Town. Nothing herein shall be construed as a waiver, limitation or release of any right or remedy that the Town may have for breach of this Agreement, which rights are cumulative and in no way limited by the warranty.

Section 2: Term of this Agreement and Agreement Time

- 2.1 Town and Contractor agree that Contractor shall perform all Work under this Agreement for

FRONTIER TRAILS PARK

- 2.2 Town shall have the ability to terminate this Agreement as provided in "Section 18: Termination."
- 2.3 Contractor shall not be entitled to any claim for damages against Town on account of hindrance or delays from any cause whatsoever. If, however, Contractor is delayed in the prosecution of the Work occasioned by an act of God, or by act or omission on the part of the Town, or due to changes ordered in the Work by Town which expand the scope and costs of the Work, such act, hindrance, or delay shall only entitle Contractor to receive an extension of time as its sole and exclusive remedy for such hindrance or delays and Contractor waives any and all other claims against Town.
- 2.4 Time being of the essence, Town and Contractor agree that Contractor shall perform all Work under this Agreement and achieve substantial completion of the Work within **one hundred and fifty (150) calendar days of the date of the Notice to Proceed**, subject to appropriate extensions of time as provided in this Agreement ("Substantial Completion Date").
- 2.4.1 Substantial Completion of the Work at the Project shall be defined as the date upon which the last of all of the following events have occurred:
- (i) All necessary approvals have been issued with respect to the Work by the appropriate governmental authorities;
 - (ii) Restoration of all utilities to operation that have been affected during performance of the Work;
 - (iii) All Work has been completed; and
 - (iv) The Town's engineer/architect of record for the Project, Town of Southwest Ranches Drainage Improvements, has issued its written acceptance of the Work performed by Contractor and executed and delivered to the Town a Certificate of Substantial Completion.
- 2.4.2 Given that the parties agree that time is of the essence with respect to this Agreement and any breach of same shall go to the essence hereof, and Contractor, in agreeing to substantially complete the Work within the time herein mentioned, has taken into consideration and made allowances for all hindrances and delays incident to its Work.

Liquidated/Delay Damages ("LD's") – In the event Contractor does not achieve Substantial Completion of the Work as defined in Paragraph 2.4.1 above, in whole or in part due to its own fault, the parties hereto acknowledge that any delay beyond the scheduled Substantial Completion Date may cause grave injury and damage to the Town by virtue of locating, moving to and paying

rent for temporary quarters, loss of use, extension of overhead costs, additional costs of design professionals and otherwise. Accordingly, the calculation of the actual damages to the Town would be uncertain and difficult if not impossible to determine. Consequently, if the Contractor has not achieved Substantial Completion of the Work within **one hundred and fifty (150) days after the issuance of the Notice to Proceed** and has not obtained written authorization for such delay, time being of the essence, then the parties hereto agree that as liquidated delay damages and not as a penalty, the Contractor shall pay to the Town an amount equal to **\$200.00** for each day or portion thereof, that the date of completion is later than the scheduled Substantial Completion Date set forth above. Contractor shall be entitled to an extension of time and relief from liquidated damages to the extent that additional out of scope work is authorized by the Town in accordance with a properly executed Change Order and such work causes a critical path delay in meeting the Substantial Completion Date set forth above. All such liquidated damage amounts, if any, shall at the Town's sole option, be paid by Contractor to Town weekly, immediately upon each such failure of Contractor to comply with the scheduled Substantial Completion Date, as set forth above. In the event that the Contractor fails to make any one or more of the payments to Town as required under this Paragraph, the Town, at its sole option, shall have the right to deduct any and all such amounts from any amounts due or to become due to Contractor.

Contractor shall achieve final completion of the Work within **thirty (30) days after the date of Substantial Completion or no later than one hundred and eighty (180) days from the issuance of the Notice to Proceed** ("Final Completion Date"). Final Completion Date is defined as the date when all punch list items have been completed as evidenced by the issuance of a written Certification of Final Completion by the Town's design professional for this Project, and all other conditions precedent to Final Completion as outlined below have been satisfied:

Contractor shall:

- (i) Deliver to the Town all warranties, final certifications and similar documentation to confirm that all necessary approvals have been issued with respect to the Work by the appropriate governmental authorities;
- (ii) Complete all Punch List items of Work;
- (iii) Remove temporary facilities from the site, along with construction tools and similar elements;
- (iv) Complete final clean-up including repair, replace and restore any items damaged by Contractor as a consequence of performing Work;
- (v) Deliver to the Town confirmation that all permits have been closed; and
- (vi) Confirm that the Town's engineer/architect of record for the Project has issued its written acceptance of the Work performed by Contractor and executed and delivered to the Town a Certificate of Final Completion.

Section 3: Compensation & Method of Payment

- 3.1 Contractor shall render all Work to the Town under the Agreement for the total not to exceed lump sum price of \$59, 324.90 Dollars ("Contract Price").
- 3.2 Town shall not be liable for any cost increases or escalation associated with labor, services, materials, equipment or any other costs that may arise during the performance of the Work. In the event the cost of the Work exceeds the amounts defined in Section 3.1 herein of the Contract Price, Contractor shall pay such excess from its own funds and Town shall not be required to pay any part

of such excess. The only exception shall be any adjustments to the Contract Price pursuant to any written Change Order duly executed by Town and Contractor in accordance with the terms and conditions of this Agreement, and with the same formality and of equal dignity associated with the original execution of this Agreement.

- 3.3 Town and Contractor agree that payment under this Agreement will be subject to (a) the delivery of an appropriate invoice or payment application by Contractor to Town with such invoices being delivered by Contractor no more often than once every 30 days, and (b) verification by Town and its designated professional that the Work being invoiced has been performed in accordance with this Agreement. Upon verification by Town and the design professional that the invoiced Work has been performed in accordance with this Agreement, Town shall have thirty (30) days thereafter to pay said invoice.
- 3.4 Each invoice or payment application must be accompanied by all supporting documentation and other information reasonably requested by Town, including, but not limited to a Partial Release of Lien or Final Release of Lien as appropriate in the forms set forth in Chapter 713.20, Florida Statutes. Reference herein to Chapter 713, Florida Statutes is for convenience, and shall not be construed as a waiver of sovereign immunity or authority for imposition of liens against public property. Each progress payment shall be reduced by 10% retainage. Subject to other requirements of the Contract Documents, retainage shall be released after final completion of the Work and Town's receipt of acceptable reports and other documentation including certification of payment to subcontractors, if any, and a Final Release of Lien in the form set forth in Section 713.20, Florida Statutes, as well as satisfaction of the conditions set forth at Section 3.5 of this Agreement.
- 3.5 A final payment invoice or application must be accompanied by written notice from Contractor that the entire Work is completed. The Town's engineer/architect of record will make a final inspection and notify Contractor in writing with a punch list of all particulars in which this inspection reveals that the Work is incomplete or defective. Contractor shall immediately take such measures as are necessary to complete the punch list and remedy deficiencies. Contractor's obligation to perform and complete the Work in strict accordance with the Contract Documents shall be absolute. The Town may refuse payment if (a) the Work is defective or completed Work has been damaged requiring correction or replacement, (b) the Town has been required to correct defective Work or complete Work in accordance with the Contract Documents, or (c) because claims have been made against the Town on account of Contractor's performance or furnishing of

the Work or liens or claims have been filed or asserted in connection with the Work or there are other items entitling the Town to a set-off against the amount due. No payment will be made for Work performed by the Contractor to replace defective work; for work which is not shown or ordered in the Contract Documents; or additional work performed by Contractor without prior written approval of Town.

Section 4: Assignment

No assignment of this Agreement or of the Work hereunder by Contractor shall be valid without the express written consent of Town, which may be given or withheld, in Town's sole discretion. All Work to be performed pursuant to this Agreement shall be performed by the Contractor, and no Work shall be subcontracted to other parties or firms without the prior written consent and approval of the Town Administrator.

Section 5: Contractor's Responsibility for Safety

- 5.1 Contractor shall be responsible for initiating, maintaining and supervising all safety precautions and programs in connection with the Work provided pursuant to this Agreement in order to prevent,

inter alia, damage, injury or loss to (a) all employees performing the Work and all other persons who may be affected thereby, (b) all the Work and all materials and equipment to be incorporated therein and (c) other property at the site or adjacent thereto. Contractor shall timely provide all notices and comply with all applicable laws, ordinances, rules, regulations and orders of any public authority or other authority with jurisdiction bearing on the safety of persons and property in order to provide protection from damage injury or loss.

Section 6: Insurance

- 6.1 Throughout the term of this Agreement and for all applicable statutes of limitation periods, Contractor shall maintain in full force and affect all of the insurance coverages as set forth in this Section.
- 6.2 All Insurance Policies shall be issued by companies that (a) are authorized to transact business in the State of Florida, (b) have agents upon whom service of process may be made in Broward County, Florida, and (c) have a rating of “A-” or better in accordance with A.M. Best’s Key Rating Guide.
- 6.3 All Insurance Policies shall name and endorse the following as an additional named insured:
Town of Southwest Ranches
13400 Griffin Road
Southwest Ranches, FL 33330-2628
- 6.4 All Insurance Policies shall be endorsed to provide that (a) Contractor's Insurance is primary to any other Insurance available to Town or any other additional insured with respect to claims covered under the policy and (b) Contractor’s insurance applies separately to each insured against who claims are made or suit is brought, and (c) that the inclusion of more than one insured shall not operate to increase the Insurer’s limit of liability. Self-insurance by Contractor shall not be acceptable as providing any of the required insurance coverages required in this Agreement.
- 6.5 If the Contractor fails to submit the required insurance certificate in the manner prescribed with the executed Agreement submitted to the Town at the time of execution of this Agreement, Contractor shall be deemed in default, and the Agreement shall be cancelled or rescinded without liability by the Town to the Contractor.
- 6.6 Contractor shall carry the following minimum types of Insurance:
- A. **WORKER'S COMPENSATION**: Worker's Compensation Insurance is to apply to all employees in compliance with the “Workers’ Compensation Law” of the State of Florida and all applicable federal laws. Contractor shall carry Worker’s Compensation Insurance with the statutory limits, which shall include employer’s liability insurance with a limit of not less than **Five Hundred Thousand Dollars (\$500,000)** for each accident, and **Five Hundred Thousand Dollars (\$500,000)** for each disease. Policy(ies) must be endorsed with waiver of subrogation against Town.
- B. **BUSINESS AUTOMOBILE LIABILITY INSURANCE**: Contractor shall carry business automobile liability insurance with minimum limits of **One Million Dollars (\$1,000,000)** per occurrence, combined single limits bodily injury liability and property damage. The policy must be no more restrictive than the latest edition of the business automobile liability policy without restrictive endorsements, as filed by the Insurance Services Office, and must include all owned vehicles and all hired or non-owned vehicles.

C. **COMMERCIAL GENERAL LIABILITY:** Contractor shall carry Commercial General Liability Insurance with limits of not less than **One Million Dollars (\$1,000,000)** per occurrence combined single limit for bodily injury and property damage, and not less than **Two Million Dollars (\$2,000,000)** in the aggregate. The insurance policy must include coverage that is no more restrictive than the latest edition of the commercial general liability policy, without restrictive endorsements as filed by the Insurance Service Office (ISO), and the policy must include coverages for premises and/or operations, independent contractors, products and/or completed operations for contracts, contractual liability, broad form contractual coverage, broad form property damage, products, completed operations, personal injury and explosion, collapse and underground (X-C-U). Personal injury coverage shall include coverage that has the employee and contractual exclusions removed. The ISO form of the policy must be acceptable to the Town.

D. **ENVIRONMENTAL POLLUTION INSURANCE:**
The Contractor shall carry an Environmental Pollution Insurance for pollution-related incidents, including the cost of cleaning up a site after a pollution incident, with limits not less than \$500,000.00 Dollars per occurrence with deductible not greater than \$100,000.00. An additional Form or endorsement to the Commercial General Liability Insurance to include an Environmental Pollution Insurance coverage providing the specified coverage, is acceptable.

6.7 Contractor shall provide Town with a copy of the Certificates of Insurance or endorsements evidencing the types of Insurance and coverages required by this Section prior to beginning the performance of any Work under this Agreement and, at any time thereafter, upon request by Town.

6.8 Contractor's Insurance Policies shall be endorsed to provide Town with at least thirty (30) calendar days prior written notice of cancellation, non-renewal, restrictions, or reduction in coverages or limits. Notice shall be sent to:

Town of Southwest Ranches
13400 Griffin Road
Southwest Ranches, Florida 33330

And

Keith M. Poliakoff, Esq.
Saul Ewing Arnstein & Lehr
200 East Las Olas Boulevard
Suite 1000
Fort Lauderdale, Florida 33301

6.9 Contractor's Commercial General Liability Insurance policy shall be on an "occurrence" basis only and shall not be a "claims-made" policy.

6.10 If any of Contractor's Insurance policies include a general aggregate limit and provides that claims investigation or legal defense costs are included in the general aggregate limit, the general aggregate limit that is required shall be at least five (5) times the occurrence limits specified above in this article.

6.11 The Contractor shall not commence operations, and/or labor to complete any of the Work pursuant to this Agreement until certification or proof of insurance issued directly by the insurance company underwriting department or insurance agent, detailing terms and provisions of coverage, has been received and approved by the Town.

- 6.12 If any of Contractor's initial insurance expires prior to the completion of the Work, renewal copies of Policies shall be furnished to Town at least thirty (30) days prior to the date of their expiration, and Town shall be an additional named insured by endorsement on all of Contractor's renewal policies.
- 6.13 **UPON EXECUTION OF THIS AGREEMENT, CONTRACTOR SHALL SUBMIT TO TOWN COPIES OF ITS CERTIFICATE(S) OF INSURANCE EVIDENCING THE REQUIRED COVERAGES REQUIRED HEREIN AND SPECIFICALLY PROVIDING THE ENDORSEMENT TO THE POLICIES THAT SHOWS THE TOWN OF SOUTHWEST RANCHES IS AN ADDITIONAL NAMED INSURED WITH RESPECT TO THE REQUIRED COVERAGES AND CONTRACTOR'S WORK UNDER THE AGREEMENT.**
- 6.14 The official title of the owner is Town of Southwest Ranches. This official title shall be used in all insurance policies and documentation.
- 6.15 All required insurance policies shall preclude any insurer's or underwriter's rights of recovery or subrogation against Town with the express intention of the parties being that the required insurance coverage protects both parties as the primary coverage for any and all losses covered by the above described insurance.
- 6.16 Contractor shall ensure that any company issuing insurance to satisfy the requirements contained in this Agreement agrees that they shall have no recourse against Town for payment or assessments in any form on any policy of insurance.
- 6.17 The clauses "Other Insurance Provisions" and "Insured Duties in the Event of an Occurrence, Claim or Suit" as it appears in any policy of insurance in which Town is named as an additional named insured shall not apply to Town in any respect. Town shall use its best efforts to provide written notice of occurrence within thirty (30) working days after Town's actual notice of such event.
- 6.18 Notwithstanding any other provisions of this Agreement, Contractor's obligation to maintain all required insurance as specified in this Section of the Agreement shall survive the expiration or earlier termination of this Agreement.

Section 7: Copyrights and Patent Rights

Contractor warrants that there has been no violation of copyrights, trademarks, or patent rights in manufacturing, producing, and/or selling the item(s) ordered or shipped as a result of this Agreement; and Contractor agrees to indemnify and hold harmless Town, its employees, agents, or servants, its employees, agents, or servants against any and all liability, loss, or expense resulting from any such violation(s).

Section 8: Laws and Regulations

Contractor agrees to abide by all applicable Federal, State, County, and local laws, rules, regulations, ordinances and codes in performing all Work under this Agreement.

Section 9: Taxes and Costs

All federal, state and local taxes relating to the Contractor's Work under this Agreement and, similarly, all costs for licenses, permits, or certifications to perform the Work under this Agreement shall be paid by the Contractor.

Section 10: Indemnification

To the fullest extent permitted by Florida law, including Florida Statutes, Section 725.06, the Contractor shall indemnify, defend and hold harmless the Town, its officers and employees, from liabilities, damages, losses and costs, including, but not limited to, reasonable attorney's fees (at both the trial and appellate levels), to the extent caused by the negligence, recklessness, or intentional wrongful misconduct of the Contractor and persons employed or utilized by the Contractor in the performance of the Contract or anyone else for whose actions Contractor may be responsible, regardless of the partial fault of any party indemnified hereunder. Notwithstanding any other provisions of this Agreement, the Contractor's duty to indemnify, defend and hold the Town harmless shall survive the termination or earlier expiration of this Agreement.

Section 11: Non-discrimination

Contractor shall not discriminate against any client, employee or applicant for employment because of race, gender, age, color, religion, sex, national origin, physical or mental disability, or marital status. Contractor shall take affirmative action to ensure that applicants, subcontractors, Independent contractors, and employees are treated without discrimination in regard to their race, gender, age, color, religion, sex, national origin, physical or mental disability, or marital status. Contractor shall comply with all applicable sections of the Americans with Disabilities Act. Contractor agrees that compliance with this Article constitutes a material condition to this Agreement, and that it is binding upon the Contractor, its successors, transferees, and assignees for the period during which any Work is provided. Contractor further assures that all subcontractors and independent contractors are not in violation of the terms of this Section of the Agreement.

Section 12: Sovereign Immunity

Nothing in this Agreement is intended nor shall it be construed or interpreted to waive or modify the Town's Sovereign Immunity defense or any other of the Town's immunities and limitations on liability as provided for in Florida Statutes, as now worded or as may hereafter be amended and all Florida case law interpreting same.

Section 13: Prevailing Party Attorneys' Fees

In the event either party to this Agreement incurs legal fees, legal expenses or costs to enforce the terms of this Agreement on trial or on appeal at all levels, the prevailing party shall be entitled to recover the reasonable costs of such action so incurred, including, without limitation, reasonable attorney's fees and costs and expert witness fees and costs incurred.

Section 14: No Third Party Beneficiaries

This Agreement is solely for the benefit of the parties hereto, and is not entered into for the benefit of any other person or entity. Nothing in this Agreement shall be deemed or construed to create or confer any benefit, right or cause of action for any third party or entity.

Section 15: Funding

The obligation of Town for payment to Contractor for the Work is limited to the availability of funds appropriated in a current fiscal period, and continuation of any contractual relationship into a subsequent fiscal period is subject to appropriation of funds, unless otherwise authorized by law.

Section 16: Manner of Performance

Contractor agrees to perform its Work in a professional manner and in accordance with all applicable Local, State, County, and Federal laws, rules, ordinances, regulations and codes. Contractor agrees that the Work provided shall be provided by employees that are educated, trained, experienced, certified, and licensed in all areas encompassed within their designated duties. Contractor agrees to furnish to Town any and all

documentation, certification, authorization, license, permit, or registration currently required by applicable laws, rules, and regulations. Contractor further certifies that it and its employees will keep all licenses, permits, registrations, authorizations, or certifications required by applicable laws or regulations in full force and effect during the term of this Agreement. Failure of Contractor to comply with this paragraph shall constitute a material breach of this Agreement.

Section 17: Public Records

The Town is subject to Chapter 119, Florida Statutes, “Public Records Law.” No claim of confidentiality or proprietary information in all or any portion of a response will be honored unless a specific exemption from the Public Law exists and is cited in the response. An incorrectly claimed exemption does not disqualify the firm, only the exemption claimed. Contractor acknowledges the public shall have access at all reasonable times, to all documents and information pertaining to Town’s contracts, subject to the provisions of Chapter 119, Florida Statutes, and agrees to allow access by the Town and the public to all documents subject to disclosures under applicable law.

To the extent that Contractor has been provided access to or has received security sensitive information, as defined by Florida Statutes, Section 119.071 and/or has executed a Confidential Information Acknowledgement and Agreement as part of the IFB process, Contractor shall keep and maintain the security sensitive information as confidential and exempt from public disclosures as required by Florida Statutes.

Contractor agrees to keep and maintain public records required by the Town to perform the service in Contractor’s possession or control in connection with Contractor’s performance under this IFB and any Contract awarded, and upon the request from the Town’s custodian of public records, to provide the Town with a copy of the requested records or allow the records to be inspected or copied within a reasonable amount of time at a cost that does not exceed the cost provided in Chapter 119 or as otherwise provided by law. Contractor shall ensure that public records that are exempt or confidential and exempt from public records disclosure requirements are not disclosed except as authorized by law for the duration of the contract term and following completion of the Contract if the Contractor does not transfer the records to the Town.

Upon completion of the Contract, Contractor agrees, at no cost to Town, to transfer to the Town all public records in possession of the Contractor or keep and maintain public records required by the Town to perform the service. If the Contractor transfers all public records to the Town upon completion of the Contract, the Contractor shall destroy any duplicate public records that are exempt or confidential and exempt from public records disclosure requirements. If the Contractor keeps and maintains public records upon completion of the Contract, the contractor shall meet all applicable requirements for retaining public records. All records stored electronically must be provided to the Town, upon request from the Town’s custodian of public records, in a format that is compatible with the information technology system of the Town.

Contractor’s failure or refusal to comply with the provisions of this section shall result in the immediate termination for cause of the Contract by Town.

IF THE CONTRACTOR HAS QUESTIONS REGARDING THE APPLICATION OF CHAPTER 119, FLORIDA STATUTES, TO THE CONTRACTOR’S DUTY TO PROVIDE PUBLIC RECORDS RELATING TO THIS CONTRACT, CONTACT THE CUSTODIAN OF PUBLIC RECORDS AT PHONE: (954) 434-0008; EMAIL:

RMUNIZ@SOUTHWESTRANCHES.ORG; RUSSELL MUNIZ, ASSISTANT TOWN ADMINISTRATOR/TOWN CLERK, TOWN OF SOUTHWEST RANCHES, 13400 GRIFFIN ROAD, SOUTHWEST RANCHES, FLORIDA, 33330.

Section 18: Termination

The Agreement may be terminated upon the following events:

- A. **Termination by Mutual Agreement.** In the event the parties mutually agree in writing, this Agreement may be terminated on the terms and dates stipulated therein.
- B. **Termination for Convenience.** This Agreement may be terminated for Convenience by Town upon Town providing Contractor with **thirty (30) calendar day's** written notice of Town's intent to terminate this Agreement for Convenience. In the event that this Agreement is terminated by Town for Convenience, Contractor shall be paid ONLY for Work performed and approved by the Town as of the date of this Agreement is terminated, plus any direct and reasonable expense sustained up to the date of receipt of the written notice. In no event shall Town be liable for consequential damages, including but not limited to, lost profits on Work not yet performed, and no other compensation or damages other than as set forth in this Section shall be paid to or recovered by Contractor in any legal proceeding against Town. Upon being notified of Town's election to terminate, Contractor shall immediately cease performing any further Work or incurring additional expenses. Contractor acknowledges and agrees that Ten Dollars (\$10.00) of the compensation to be paid by Town, the adequacy of which is hereby acknowledged by Contractor, is given as specific consideration to Contractor for Town's right to terminate this Agreement for Convenience.
- C. **Termination for Cause.** In the event of a material breach by Contractor, Town shall provide Contractor written notice of its material breach. Contractor shall thereafter have fourteen (14) days from the date of its receipt of such notification to cure such material breach. If Contractor does not cure the material breach within that time period, Town may terminate this Agreement immediately. Material breaches shall include, but are not limited to, Contractor's violations of governing standards, failure to carry out the work in strict accordance with the Contract Documents, failure to supply sufficient work forces, violations of state or federal laws, violation of Town's policies and procedures, or violation of any of the terms and conditions of this Agreement. In the event that Town elects to terminate Contractor for cause as provided for in this Section, and Town's termination for cause is later determined by a court of competent jurisdiction to be improper, or in any other way wrongful or in breach of this Agreement, the termination will be automatically deemed converted to one for Convenience, and Contractor shall solely be paid and Contractor's damages are solely limited to the compensation Contractor would be entitled to pursuant to subparagraph (B) of this Section.
- D. **Termination for Lack of Funds.** In the event the funds to finance the Work under this Agreement become unavailable or other funding source applicable, Town may provide Contractor with thirty (30) days written notice of termination. Nothing in this Agreement shall be deemed or construed to prevent the parties from negotiating a new Agreement in this scenario. In the event that Town elects to terminate Contractor for lack of funds as provided for in this Section, and Town's termination for lack of funds is later determined by a court of competent jurisdiction to be improper, or in any other way wrongful or in breach of this Agreement, the termination will be automatically deemed converted to one for Convenience, and Contractor shall solely be paid and Contractor's damages are solely limited to the compensation Contractor would be entitled to pursuant to subparagraph (B) of this Section.

E. **Immediate Termination by Town.** In addition to any other grounds stated herein, Town, in its sole discretion, may terminate this Agreement immediately upon the occurrence of any of the following events:

1. Contractor's violation of the Public Records Act;
2. Contractor's insolvency, bankruptcy or receivership;
3. Contractor's violation or non-compliance with Section 11 of this Agreement;
4. Contractor's failure to maintain any Insurance required by Section 6 of this Agreement; or
5. Contractor's violation of Section 19 of this Agreement.

Section 19: Public Entity Crimes Information Statement

Pursuant to Florida Statutes, Section 287.133: "A person or affiliate who has been placed on the convicted vendor list following a conviction for public entity crime may not submit a bid on a contract to provide any goods or services to a public entity, may not submit a bid on a contract with a public entity for the construction or repair of a public building or public work, may not submit bids on leases of real property to public entity, may not be awarded or perform work as a contractor, supplier, subcontractor, or consultant under a contract with any public entity, and may not transact business with any public entity in excess of the threshold amount provided in Section 287.017, for CATEGORY TWO for a period of 36 months from the date of being placed on the convicted vendor list." Violation of this section by Contractor shall result in Town's immediate termination of this Agreement.

Section 20: Use of Awarded Bid by Other Governmental Units

Contractor agrees that this Agreement may be utilized by other governmental entities or units to provide the specified services. Town does not become obligated in any way, to pay for or become, in any way, responsible or liable for Contractor's provision of Work or services to any other governmental unit.

Section 21: Change Orders and Modification of Agreement

Town and Contractor may request changes that would increase, decrease or otherwise modify the Scope of Work to be provided under this Agreement. Such changes only become part of this Agreement and increase, decrease or otherwise modify the Work or the Contract Price under this Agreement if evidenced by a written Change Order executed by Town and Contractor, with the same formality and of equal dignity associated with the original execution of the Agreement.

Section 22: No Waiver of Rights

Neither the Town's review, approval or payment for any of the Work required under this Agreement shall be construed to operate as a waiver of any of Town's rights under this Agreement or of any causes of action arising out Contractor's performance of the Work under this Agreement, and Contractor shall be and remain liable to the Town for all damages to the Town caused by the Contractor's negligent or improper performance of any of the Work furnished under this Agreement, irrespective of the Town's review, approval or payment for any of the Work under this Agreement. The rights and remedies of the Town provided for under this Agreement are in addition to all other rights and remedies provided to Town by law.

Section 23: Jurisdiction and Venue

The exclusive venue for any litigation arising from or relating to the Agreement shall be in a court of competent jurisdiction in the 17th Judicial Circuit in and for Broward County, Florida. This Agreement shall be governed by the substantive laws of the State of Florida.

Section 24: WAIVER OF RIGHT TO JURY TRIAL

BY ENTERING INTO THIS AGREEMENT, CONTRACTOR AND TOWN HEREBY EXPRESSLY WAIVE ANY RIGHTS EITHER PARTY MAY HAVE TO A TRIAL BY JURY IN ANY CIVIL LITIGATION RELATED TO, OR ARISING OUT OF THIS AGREEMENT.

Section 25: Gender

Wherever the context shall so require, all words herein in the masculine gender shall be deemed to include the feminine, and all words herein in the feminine gender shall be deemed to include the masculine. All singular words shall include the plural, and all plural words shall include the singular.

Section 26: Time is of the Essence; Liquidated Damages

Time is of the essence for all of Contractor's obligations under this Agreement. The Town will be entitled to Liquidated Damages as set forth at Section 2.4.2.

Section 27: Days

The terms "days" as referenced in this Agreement shall mean consecutive calendar days.

Section 28: Written Mutual Agreement

This Agreement is binding upon the parties hereto, their successors and assigns, and replaces and supersedes any and all prior agreements or understanding between the parties hereto whether written or oral which are merged herein.

Section 29: No Amendment or Waiver

This Agreement may not be changed, altered or modified except by an instrument in writing signed by all parties hereto, with the same formality and of equal dignity as the execution of this Agreement prior to the initiation of any Work reflecting such change.

Section 30: Severability

In the event any term or provision of this Agreement shall be determined by appropriate judicial authority to be illegal or otherwise invalid, such provision shall be given its nearest legal meaning so as to remain in full force and effect, or be deemed severed from the Agreement so as not to affect the validity or enforceability of the remaining provisions of the Agreement. In case any one or more of the provisions of this Agreement shall be determined by appropriate judicial authority to be invalid, illegal or unenforceable, in any respect, the validity of the remaining provisions of this Agreement shall be in no way affected, prejudiced, or disturbed thereby.

Section 31: Resolution of Disputes; Florida Statutes, Chapter 558 Not Applicable

To prevent litigation, it is agreed by the parties hereto that Town Administrator shall solely decide all questions, claims, difficulties and disputes of, whatever nature, which may arise relative to this Agreement, including but not limited to, Contractor's fulfillment of its obligations under this Agreement as to the character, quality, amount and value of any Work done and materials furnished, or proposed, to be done or furnished, under or by reason of, the Agreement. Further, to the extent required or permitted by the agreement between the Town and its design professional for this Project, the design professional shall have access to the Work, the right to conduct testing or inspections, to reject non-conforming work, and to review pay applications. The Town Administrator's decision shall be reduced to writing, and a copy furnished to the Contractor within a reasonable time following submission to the Town of the question, claim, difficulty or dispute as referenced above. The Town Administrator's decision shall be final and conclusive. Additionally, the parties understand and agree that Florida Statutes, Chapter 558 does not apply to this Agreement or the Work, and that the parties hereby "opt out" of the procedures set forth at Chapter 558.

Section 32: Notice

Whenever either party desires to give notice unto the other, such notice must be in writing by certified or registered mail, postage prepaid, return receipt requested, hand delivery, or facsimile transmission prior to 5:00 p.m. on the date of transmission (e.d.t. or e.s.t. as applicable), or via overnight express courier service. For the present, the parties designate the following individuals as the respective parties and places for giving of notice:

If to Town:

Town of Southwest Ranches
Town Administrator
13400 Griffin Road
Southwest Ranches, Florida 33330

With a copy to:

Keith M. Poliakoff, Esq.
Saul Ewing Arnstein & Lehr
200 East Las Olas Boulevard
Suite 1000
Fort Lauderdale, Florida 33301

If to Contractor:

Section 33: Miscellaneous

A. Ownership of Documents. Unless otherwise provided by law, any and all reports, surveys, and other data and documents provided or created in connection with this Agreement by Contractor and all persons or entities employed or otherwise retained by Contractor are and shall remain the property of Town. In the event of termination of this Agreement for any reason, any reports, photographs, surveys and other data and documents prepared by Contractor, whether finished or unfinished, shall become the property of Town and shall be delivered by Contractor to the Town Administrator within seven (7) days of termination of this Agreement for any reason. Any compensation due to Contractor shall be withheld until all documents are received by Town as provided herein.

B. Audit and Inspection Rights and Retention of Records. Town shall have the right to audit the books, records and accounts of Contractor that are related to this Agreement. Contractor shall keep such books, records, and accounts as may be necessary in order to record complete and correct entries related to this Agreement.

Contractor shall preserve and make available, at reasonable times for examination and audit by Town, all financial records, supporting documents, statistical records, and any other documents pertinent to this Agreement for the required retention period of the Florida Public Records Act (Chapter 119, Florida Statutes), if applicable, or, if the Florida Public Records Act is not applicable, for a minimum period of three (3) years after expiration or earlier termination of this Agreement, unless Contractor is notified in writing by Town of the need to extend the retention period. Such retention of such records and documents shall be at Contractor's sole expense. If any audit has been

initiated and audit findings have not been resolved at the end of the retention period or three (3) years, whichever is longer, the books, records, and accounts shall be retained until resolution of the audit findings. If the Florida Public Records Act is determined by Town to be applicable to Contractor's records, Contractor shall comply with all requirements thereof.

However, no confidentiality or non-disclosure requirement of either federal or state law shall be violated by Contractor. Any incomplete or incorrect entry in such books, records, and accounts shall be a basis for Town's disallowance and recovery of any payment upon such entry. In addition, Contractor shall respond to the reasonable inquiries of successor Contractors and allow successor Contractors to receive working papers relating to matters of continuing significance. In addition, Contractor shall provide a complete copy of all working papers to the Town, prior to final payment by the Town under this Agreement.

C. Independent Contractor. Contractor is an independent contractor of Town under this Agreement. Services provided by Contractor pursuant to this Agreement shall be subject to the supervision of Contractor. In providing such services, neither Contractor nor its agents shall act as officers, employees or agents of the Town. Personnel policies, tax responsibilities, social security and health insurance, employee benefits, purchasing policies and other similar administrative procedures applicable to the Work and services rendered under this Agreement shall be exclusively and solely those of Contractor. This Agreement shall not constitute or make Town and Contractor a partnership or joint venture.

D. Conflicts. Neither Contractor nor its employees shall have or hold any continuing or frequently recurring employment or contractual relationship that is substantially antagonistic or incompatible with Contractor's loyal and conscientious exercise of judgment related to its performance under this Agreement. Contractor agrees that none of its officers or employees shall, during the term of this Agreement, serve as an expert witness against Town in any legal or administrative proceeding in which he or she is not a party, unless compelled by court process. Further, Contractor agrees that such persons shall not give sworn testimony or issue a report or writing, as an expression of his or her expert opinion, which is adverse or prejudicial to the interests of Town in connection with any such pending or threatened legal or administrative proceeding. The limitations of this section shall not preclude Contractor or any other persons from representing themselves in any action or in any administrative or legal proceeding.

In the event Contractor is permitted to utilize subcontractors to perform any services required by this Agreement, Contractor agrees to prohibit such subcontractors, by written contract, from having any conflicts within the meaning of this Section.

E. Contingency Fee. Contractor warrants that it has not employed or retained any company or person, other than a bona fide employee working solely for Contractor, to solicit or secure this Agreement and that it has not paid or agreed to pay any person, company, corporation, individual or firm, other than a bona fide employee working solely for Contractor, any fee, commission, percentage, gift, or other consideration contingent upon or resulting from the award or making of this Agreement. For a breach or violation of this provision, Town shall have the right to terminate this Agreement without liability and, at its discretion, to deduct from the Agreement price or otherwise recover the full amount of such fee, commission, percentage, gift or consideration.

F. Materiality and Waiver of Breach. Town and Contractor agree that each requirement, duty, and obligation set forth herein is substantial and important to the formation of this Agreement and, therefore, is a material term hereof. Town's failure to enforce any provision of this Agreement shall not be deemed a waiver of such provision or modification of this Agreement. A waiver of any

breach of a provision of this Agreement shall not be deemed a waiver of any subsequent breach and shall not be construed to be a modification of the terms of this Agreement.

- G. Joint Preparation.** Town and Contractor both acknowledge that they have sought and received whatever competent advice and legal counsel as was necessary for them to form a full and complete understanding of all rights and obligations herein and that the preparation of this Agreement has been their joint effort. The language agreed to herein express their mutual intent and the resulting document shall not, solely as a matter of judicial construction, be construed more severely against one of the parties than the other.
- H. Drug-Free Workplace.** Contractor shall maintain a drug-free workplace.
- I. Headings.** Headings are for convenience of reference only and shall not be considered in any interpretation of this Agreement.
- J. Binding Authority.** Each person signing this Agreement on behalf of either party individually warrants that he or she has full legal power to execute this Agreement on behalf of the party for whom he or she is signing, and to bind and obligate such party with respect to all provisions contained in this Agreement.
- K. Truth-in-Negotiation Certificate.** Signature of this Agreement by Contractor shall act as the execution of a truth-in-negotiation certificate stating that wage rates and other factual unit costs supporting the compensation of this Agreement are accurate, complete, and current at the time of contracting.

[Signatures on next page]

TOWN OF SOUTHWEST RANCHES, FLORIDA
FRONTIER TRAILS PARK
IFB No. 19-001

IN WITNESS WHEREOF, the parties have made and executed this Agreement on the respective dates under each signature: _____, and the TOWN OF SOUTHWEST RANCHES, signing by and through its Mayor duly authorized to execute same by Council action on the 24th day of January 2019.

WITNESSES:

CONTRACTOR:

By: _____
_____, _____ (title)
____ day of _____ 201__

TOWN OF SOUTHWEST RANCHES

By: _____
Doug McKay, Mayor
____ day of _____ 201__

By: _____
Andrew D. Berns, Town Administrator
____ day of _____ 201__

ATTEST:

Russell Muñiz, Assistant Town Administrator/Town Clerk

APPROVED AS TO FORM AND CORRECTNESS:

Keith M. Poliakoff, Town Attorney



NOTES:

SEE BOUNDARY SURVEY TITLED "FRONTIER TRAILS" DATED 3/08/04 PROVIDED BY:



ELEVATIONS SHOWN ARE REFER TO NORTH AMERICAN VERTICAL DATUM (1988). THE CONVERSION FROM N.A.V.D. (1988) TO N.G.V.D. (1929) IS N.A.V.D. (1988) + 1.51' = N.G.V.D. (1929).

BOUNDARY SURVEY REFERENCES BENCH MARK: BROWARD COUNTY BENCH MARK NO. 1366, ELEVATION 5.26 N.A.V.D.

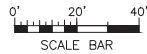

ALL RIGHTS RESERVED: No part of this publication may be reproduced, stored in a retrieval system, or transmitted, in any form or by any means, electronic, mechanical, photocopying, recording, or by any information storage and retrieval system, without the prior written permission of DDAAM.

Designed: _____
 Drawn: _____
 Checked: _____

No.	Revisions	Date	By

60255.08

 ERDMAN ANTHONY
 6400 OCEANSHORE BOULEVARD, SUITE 200
 FORT LAUDERDALE, FL 33309
 TEL: 954.576.1313 FAX: 954.576.1314

FRONTIER TRAILS PARK
 SOUTHWEST RANCHES, FLORIDA
 EXISTING CONDITIONS

DANA I GILLETTE
 FL PE 41913

Sheet Reference Number
 C-03
 Sheet ___ of ___

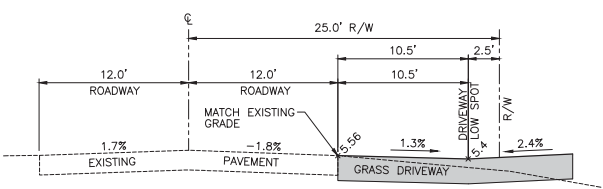
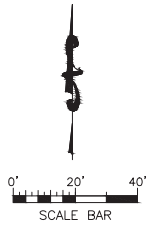

SECTION B-B
(TYPICAL GRASS DRIVE DETAIL)

All rights reserved. No part of this publication may be reproduced, stored in a retrieval system, or transmitted in any form or by any means, electronic, mechanical, photocopying, recording, or by any information storage and retrieval system, without the prior written permission of DDAW.

By: _____
 Designed: _____
 Drawn: _____
 Checked: _____

No.	Date	By	Revisions

60255.08

ERDMAN ANTHONY
 4600 OCEAN DRIVE, SUITE 200
 BOCA RATON, FL 33433
 TEL: 561-995-1234 FAX: 561-995-1234

FRONTIER TRAILS PARK
 SOUTHWEST RANCHES, FLORIDA
 SITE PLAN

DANA I GILLETTE
 FL PE 41913

Sheet Reference
 Number
 C-04
 Sheet ___ of ___

PAVING AND DRAINAGE NOTES:

1. CLEARING AND GRUBBING – WITHIN THE LIMITS OF CONSTRUCTION, ALL VEGETATION AND ROOT MATERIAL SHALL BE REMOVED.
2. UNSUITABLE SOILS – WHEN VEGETATION, DEBRIS, CONCRETE, MUCK, PEAT OR OTHER UNSUITABLE MATERIAL ARE ENCOUNTERED, THEY SHALL BE COMPLETELY REMOVED FROM THE CONSTRUCTION AREA. WHEN GUMBO OR OTHER PLASTIC CLAYS ARE ENCOUNTERED, THEY SHALL BE REMOVED WITHIN THE CONSTRUCTION AREA ONE FOOT BELOW THE SUBGRADE EXTENDING HORIZONTALLY TO THE EDGE OF THE PAVEMENT.
3. COMPACTED SUBGRADE – 12" MINIMUM THICK. SUBGRADE SHALL BE UNIFORMLY GRADED CLEAN MATERIAL COMPACTED TO 98% OF MAXIMUM DENSITY PER ASSHTO T-180.
4. BASE –
 - A) (LIMEROCK) – APPROVED LOCAL LIMEROCK BASE MATERIAL SHALL HAVE A LIMEROCK BEARING RATIO (LBR) 100 AND SHALL BE COMPACTED TO NOT LESS THAN 98% MAXIMUM DENSITY AS DETERMINED BY AASHTO T-180-86 SPECIFICATIONS AND AS CALLED FOR IN THE LATEST EDITION OF FDOT STANDARDS SPECIFICATIONS FOR ROAD & BRIDGE CONSTRUCTION SECTION 200. THE BASE SHALL BE PLACED AND COMPACTED IN TWO (2) EQUAL LAYERS.
 - B) (CRUSHED CONCRETE) – AN OPTIONAL BASE COURSE MATERIAL OF CRUSHED CONCRETE THAT IS FREE FROM STEEL REINFORCEMENT AND INCLUDES LESS THAN 7% ASPHALTIC PAVEMENT, GLASS FOUNDRY OR STEEL MILL SLAG, ASH OR POTTERY AND A PLASTICITY INDEX OF 3 OR LESS. CRUSHED CONCRETE SHALL CONFORM TO THE LATEST EDITION OF FDOT STANDARDS SPECIFICATIONS FOR ROAD & BRIDGE CONSTRUCTION SECTION 901, AND ALL ASSOCIATED SPECIFICATIONS.
5. PRIME COAT – BITUMINOUS PRIME COAT SHALL CONFORM WITH THE REQUIREMENTS OF THE LATEST EDITION OF FDOT STANDARDS SPECIFICATIONS FOR ROAD & BRIDGE CONSTRUCTION, SECTION 300, AND SHALL BE APPLIED AT THE RATE OF 0.10 GALLONS/SQUARE YARD, UNLESS A LOWER RATE IS APPROVED BY THE ENGINEER.
6. TACK COAT – BITUMINOUS TACK COAT SHALL CONFORM WITH THE REQUIREMENTS OF THE LATEST EDITION OF FDOT STANDARDS SPECIFICATIONS FOR ROAD & BRIDGE CONSTRUCTION SECTION 300, AND SHALL BE APPLIED AT THE RATE OF 0.08 GALLONS/SQUARE YARD, UNLESS A VARIATION IN RATE IS APPROVED BY THE ENGINEER.
7. SURFACE COURSE – TYPE S-III ASPHALTIC CONCRETE OR SUPERPAVE 9.5 SURFACE COURSE SHALL CONFORM WITH THE REQUIREMENTS OF THE FDOT STANDARDS SPECIFICATIONS FOR ROAD & BRIDGE CONSTRUCTION, SECTION 334.
8. SAW CUTS – ALL PAVEMENT CONNECTIONS TO EXISTING PAVEMENT SHALL BE MADE WITH A STRAIGHT SAW CUT TO THE EXISTING PAVEMENT.
9. CONCRETE – CONCRETE USED ON SITE SUCH AS CURBS, SIDEWALKS, RETAINING WALLS, ETC. SHALL DEVELOP A MINIMUM 2500 PSI, 28 DAYS COMPRESSIVE STRENGTH.
10. CONCRETE – ALL CONCRETE SHALL REQUIRE 6" THICK CONCRETE. WALKS SHALL COMPLY WITH THE LATEST EDITIONS OF FDOT DESIGN STANDARDS INDEX 310 AND 304 AND FDOT STANDARDS SPECIFICATIONS FOR ROAD & BRIDGE CONSTRUCTION SECTION 522.
11. ALL DIMENSIONS AND RADI ARE TO THE EDGE OF PAVEMENT, UNLESS OTHERWISE NOTED. ALL DIMENSIONS SHOWN TO BUILDINGS ARE TO OUTSIDE FACE OF BUILDING.
12. CONTRACTOR SHALL SAWCUT, TACK AND MATCH EXISTING PAVEMENT AT LOCATIONS WHERE NEW PAVEMENT MEETS EXISTING.
13. GRASS – INSTALL 1-1/4" OF TOPSOIL AND BAHIA SOD IN ACCORDANCE WITH FDOT SPECIFICATIONS 981.
14. ALL SOD TO BE ARGENTINE BAHIA, OR AS OTHERWISE NOTED, FREE OF PEST-, DISEASE-, AND WEED-INFESTATION OR STRESS.
15. SOD SHALL BE PLACED OVER WEED-FREE, FINE-GRADED AND HAND-RAKED AREAS. GROUND SHALL BE FREE OF ALL DEBRIS, VISIBLE ROCKS, AND LOW OR HIGH SPOTS. SOD SHALL BE LAID WITH TIGHT JOINTS, THEN TAMPED OR ROLLED AND TOP-DRESSED WITH LAWN SAND.
16. ON SLOPES EXCEEDING 3:1, PLACE LENGTH OF SOD PERPENDICULAR TO SLOPE DIRECTION, PEG SOD OR OTHERWISE ENSURE ITS ESTABLISHMENT ON SLOPES. WHERE SOD MEETS A MULCHED BED, THE CUT EDGE SHALL BE EVEN AND SHARP.
17. SOD LEVEL SHALL NOT IMPEDE WATER FLOW FROM ADJACENT SURFACES. IN AREAS WHERE PAVED SURFACES ABUT SOD OR MULCH, THE FINAL GRADE LEVEL OF BOTH SURFACES SHALL BE LEVEL.
18. WATERING: CONTRACTOR SHALL BE RESPONSIBLE FOR WATERING TURFGRASS SOD IMMEDIATELY DURING AND AFTER INSTALLATION TO PREVENT DRYING. IT SHALL THEN BE THOROUGHLY IRRIGATED TO A DEPTH SUFFICIENT THAT THE UNDERSIDE OF THE NEW TURFGRASS SOD PAD AND SOIL IMMEDIATELY BELOW THE TURFGRASS SOD ARE THOROUGHLY WET. THE CONTRACTOR SHALL BE RESPONSIBLE FOR HAVING ADEQUATE WATER AVAILABLE AT THE SITE PRIOR TO AND DURING INSTALLATION OF THE TURFGRASS SOD.
19. THE CONTRACTOR SHALL BE RESPONSIBLE FOR MAINTAINING THE SODDED TURFGRASS AND OTHER PLANTED AREAS UNTIL THE DATE OF FINAL COMPLETION AS APPROVED BY THE TOWN.

All rights reserved. No part of this publication may be reproduced, stored in a retrieval system, or transmitted in any form or by any means, electronic, mechanical, photocopying, recording, or by any information storage and retrieval system, without the prior written permission of the publisher.

© 2018 Estimote Academy

Designed: _____
 Drawn: _____
 Checked: _____

No.	By	Date	Revisions

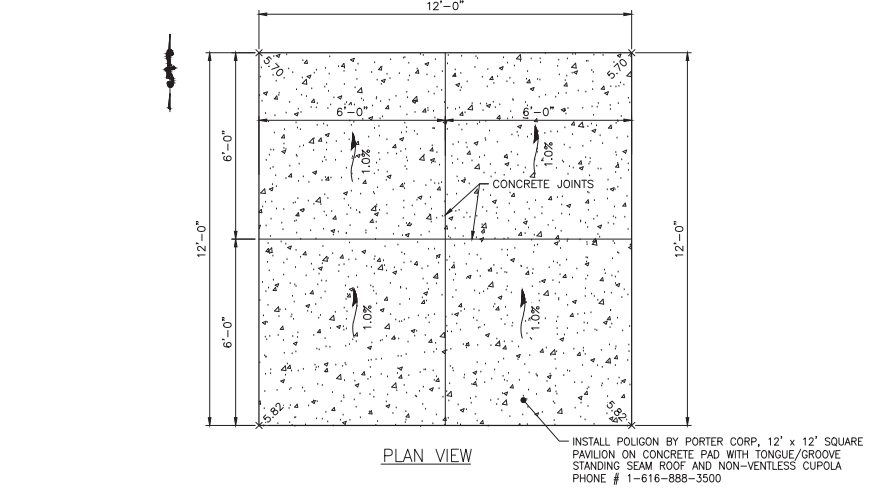

- NOTES:**
1. CONCRETE SHALL CONFORM TO FDOT STANDARD SPECIFICATIONS FOR ROAD, BRIDGE CONSTRUCTION 522 LATEST VERSION.
 2. CONCRETE PAD TO BE BROOM FINISHED WITH EVEN, DUSTLESS SURFACE.

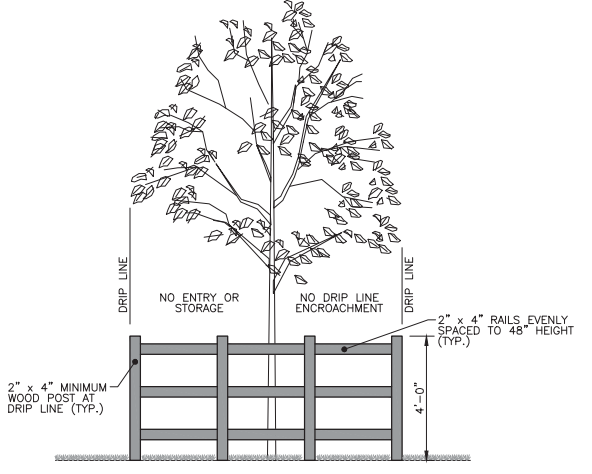

- TREE PRESERVATION NOTES:**
1. THE CONTRACTOR SHALL FAMILIARIZE HIMSELF WITH THE PROVISIONS OF THE SOUTHWEST RANCHES CODE OF ORDINANCES, CHAPTER 10 TO ENVIRONMENT, ARTICLE II TREE PRESERVATION, AND SHALL MAKE EVERY EFFORT OUTLINED THEREIN TO PREVENT DAMAGE TO EXISTING TREES, INCLUDING BUT NOT LIMITED TO THE INSTALLATION OF TREE PROTECTION BARRIERS AS SPECIFIED IN THE ORDINANCE.
 2. PRIOR TO THE PERFORMANCE OF WORK UNDER THIS CONTRACT, CONTRACTOR SHALL PROVIDE WRITTEN NOTIFICATION TO TOWN OF TREE PROTECTION EFFORTS TO BE TAKEN AND IDENTIFY ANY CONFLICTS, CONSTRAINTS OR LIMITS.
 3. WORK TO BE PERFORMED UNDER THIS CONTRACT SHALL NOT INCLUDE ACTIVITIES IDENTIFIED IN THE ORDINANCE AS GENERAL PROHIBITIONS, INCLUDING BUT NOT LIMITED TO CHANGES IN GRADE, ROOT COMPACTION, WOUNDING OF TRUNKS OR CANOPY STRUCTURES. PRUNING OR REMOVAL AS REQUIRED TO FACILITATE CONSTRUCTION MAY ONLY BE PERFORMED UPON PERMITTING BY THE TOWN AS THE CONTROLLING AGENCY, IN ACCORDANCE WITH THE ORDINANCE, AND HALL BE THE SOLE RESPONSIBILITY OF THE CONTRACTOR.
 4. IF DAMAGE OCCURS FROM WORK PERFORMED UNDER THIS CONTRACT, RESPONSIBILITY FOR ALL REQUIRED REMEDIATION OF SAID DAMAGE SHALL BE THE CONTRACTOR'S EXPENSE.

60255.08

ERDMAN ANTHONY

6400 OCEANBLVD, SUITE 200
 BOCA RATON, FL 33433
 TEL: 561-996-1313

FRONTIER TRAILS PARK
 SOUTHWEST RANCHES, FLORIDA

DETAILS

DANA I GILLETTE
 FL PE 41913

Sheet Reference Number
 C-06
 Sheet ___ of ___

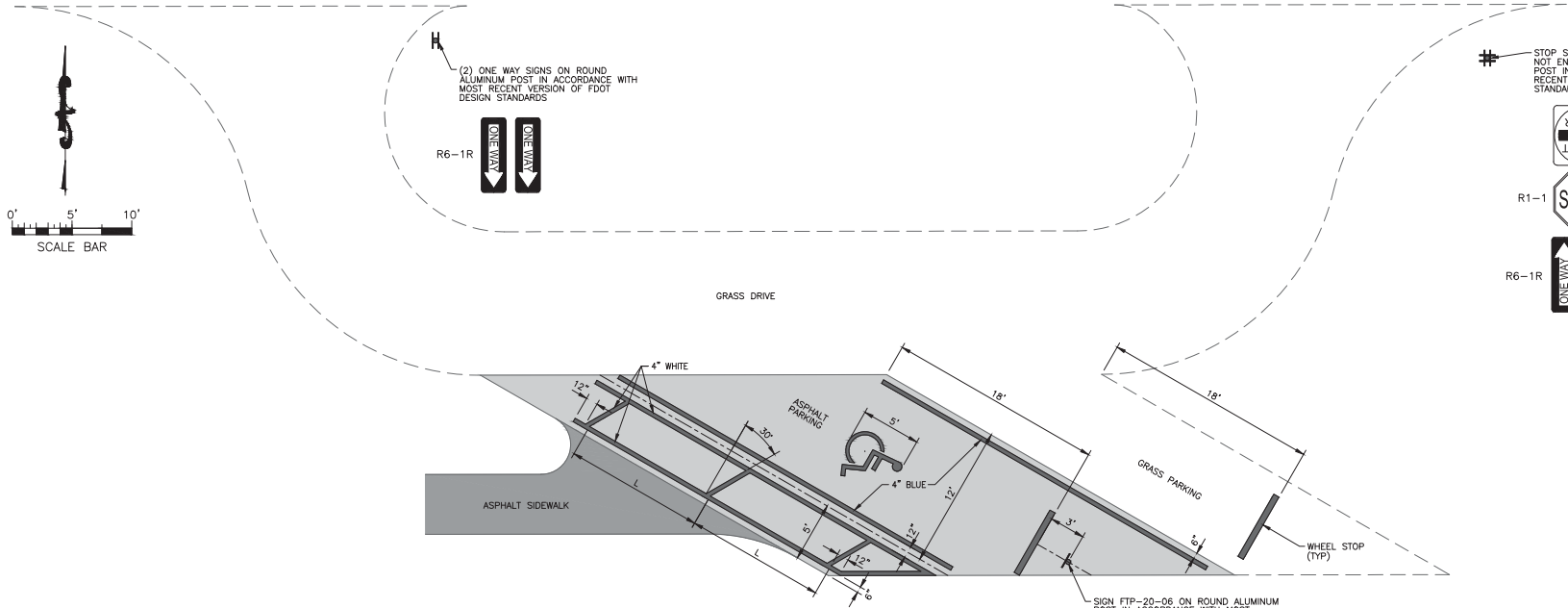

SIGNING AND PAVEMENT PARKING PLAN

STOP SIGN, (2) ONE WAY SIGNS & DO NOT ENTER SIGN ON ROUND ALUMINUM POST IN ACCORDANCE WITH MOST RECENT VERSION OF FDOT DESIGN STANDARDS

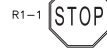

ALL RIGHTS RESERVED. No part of this publication may be reproduced, stored in a retrieval system, or transmitted, in any form or by any means, electronic, mechanical, photocopying, recording, or by any information storage and retrieval system, without the prior written permission of DDMW.

Designed: _____
 Drawn: _____
 Checked: _____

No.	Date	By	Revisions

60255.08

ERDMAN ANTHONY
 4400 ONE CENTRE DRIVE, SUITE 200
 BOCA RATON, FL 33433
 TEL: 561-995-1300 FAX: 561-995-1304

FRONTIER TRAILS PARK
 SOUTHWEST RANCHES, FLORIDA
 SIGNING AND PAVEMENT MARKING

DANA I GILLETTE
 FL PE 41913

Sheet Reference Number
 C-07
 Sheet ___ of ___

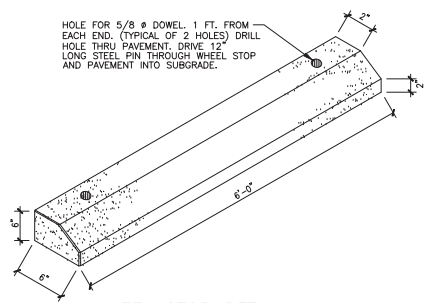

WHEEL STOP DETAIL
 NOT TO SCALE

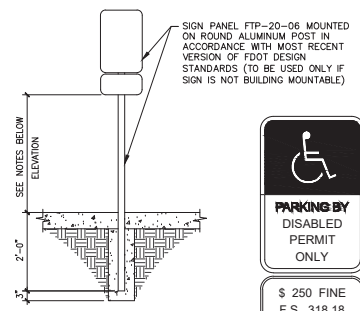

NOTES:

- SIGN POST FOUNDATION DESIGN PER FDOT 175 MPH WIND LOAD RATING.
- DIMENSION HEIGHT OF SIGN IS 60"-72" ABOVE SIDEWALK FOR SIGNS MOUNTED ON FACE OF BUILDING AND POST MOUNTED SIGNS.

TYPICAL PARKING SIGN
 NOT TO SCALE

TOWN OF SOUTHWEST RANCHES, FLORIDA
FRONTIER TRAILS PARK
IFB No. 19-001

BID SCHEDULE

The undersigned hereby proposes to furnish all labor, equipment and materials necessary to complete the work in strict accordance with the Contract Documents, schedules and plans, and all addenda, if issued, for the lump sum price shown below.

ITEM No.	ITEM DESCRIPTION	QUANTITY	UNIT	UNIT PRICE	TOTAL PRICE
GENERAL CONDITIONS					
1	MOBILIZATION/DEMobilIZATION AND GENERAL REQUIREMENTS (BONDS, PHOTOS, PERMITS, MOT)	1	LS	7999	7999
2	LAYOUT, SURVEY & RECORD DRAWINGS	1	LS	2000	2000
3	NPDES COMPLIANCE	1	LS	1000	1000
4	TESTING	1	ALLOW	1000	1000
GENERAL CONDITIONS SUBTOTAL					
CONSTRUCTION					
5	CUT/FILL/GRADE	1	LS	5000	5000
6	ASPHALT PARKING AND SIDEWALK (1.5" THICK)	6.5	TON	211	1372
7	CONCRETE PAD (6" THICK)	16	SY	50	800
8	LIMEROCK BASE (8" THICK)	65	CY	83	5395
9	COMPACTED SUBGRADE (12" THICK)	290	SY	4	1160
10	WHEEL STOP	2	EA	83	166
11	SIGNAGE	3	EA	360	1080
12	PAVEMENT MARKINGS	1	LS	1000	1000
CONSTRUCTION SUBTOTAL					
LANDSCAPING					
13	SOD	596	SY	4	2384
14	FAKAHATCHEE GRASS PLANTINGS	35	EA	10	350
15	FERTILIZER, MULCH, PLANTING, SOIL, WATER, MAINTENANCE	1	LS	1000	1000
LANDSCAPING SUBTOTAL					
PAVILION					
16	PURCHASE, SHIPPING, ENGINEERING (SEE EXHIBIT)	1	LS	\$ 16,913.90	\$ 16,913.90
17	INSTALLATION	1	LS	\$ 10,705.00	\$ 10,705.00
PAVILION SUBTOTAL					
\$ 27,618.90					
SCHEDULE OF BID ITEMS					
GENERAL CONDITIONS SUBTOTAL				11,999	
CONSTRUCTION SUBTOTAL				15,973	
LANDSCAPING SUBTOTAL				3,734	
PAVILION SUBTOTAL				\$ 27,618.90	
TOTAL				59,324.90	

BIDDER: PHE CONSTRUCTION, INC.



Town of Southwest Ranches
13400 Griffin Road
Southwest Ranches, FL 33330-2628

(954) 434-0008 Town Hall
(954) 434-1490 Fax

Town Council
Doug McKay, Mayor
Gary Jablonski, Vice Mayor
Freddy Fisikelli, Council Member
Bob Hartmann, Council Member
Denise Schroeder, Council Member

Andrew D. Berns, Town Administrator
Keith M. Poliakoff, JD, Town Attorney
Russell Muniz, Assistant Town Administrator/Town Clerk
Martin D. Sherwood, CPA, CGMA, CGFO, Town Financial Administrator

COUNCIL MEMORANDUM

TO: Honorable Mayor McKay and Town Council
VIA: Andrew D. Berns, Town Administrator
FROM: Martin D. Sherwood, Town Financial Administrator
DATE: 2/28/2019
SUBJECT: Proposed FY 2019-2020 Budget Calendar

Recommendation

It is recommended that the Town Council approve the FY 2019-2020 budget calendar, subject to comment and discussion (Attachment A).

Unanimous Vote of the Town Council Required?

No

Strategic Priorities

A. Sound Governance

Background

Budget preparation is designed to assist Town's Management in the development of short-term and long-term plans to meet policy and legal directives. Appropriately, the Town Council provides policy directives which are the principal focus of each budget process. Further, there is a need to recognize our residents, Advisory Boards, and commercial business concerns relative to the budget and obtain their input to the maximum extent feasible.

Fiscal Impact/Analysis

Budget preparation begins with the development of instructions and general policy directives to Departments as well as Advisory Board Liaisons. Documents and policies resulting from discussions are then presented to each department/advisory board liaison as a means of soliciting their identified needs and resources. Departments/advisory board liaisons are ultimately responsible for identifying, researching, developing, and submitting requests for

operating funds, any new programs, capital improvements, and personnel changes.

For the past seven years, the Town of Southwest Ranches has developed operating costs based on a zero-based budget model. Departments are encouraged to review prior spending as a way of reminding themselves of on-going obligations. However, each request for funding must be accompanied by a detailed justification. Further, revenue projections must be accurate and reflect current economic conditions.

For Budget calendar FY 2019-2020 and similar to last fiscal year, it is proposed that during most of March and April thru May 20th, the Town Administrator and Town Financial Administrator meet individually with Town Council members to obtain policy direction. Also, in March thru April, the funding recommendations are assembled, reviewed, and then eventually presented to the Town Administrator and Town Attorney in mid-May for further evaluation. Thereafter, during July the budget documents are assembled and prepared for distribution. Also, a Preliminary Millage Rate and the Initial Fire Protection and Solid Waste special assessment is adopted at the second July regular Council meeting.

During August, the Council will be updated, provide further direction on policy assumptions and modifications/revisions to program priorities during a public budget workshop (Tuesday, August 20th @ 7:00PM) that will also provide a forum for community input. The public is invited to attend and participate, but the meeting is not considered a formal public hearing. The budget workshop also provides an opportunity for the Town Council to seek clarification on proposed items, often from Department Directors/Staff, and to provide further policy direction to the Town Administrator and Town Financial Administrator.

It is important to note that several periods of revision may be required as the Broward Property Appraiser does not release certified rates until July 1 and the Florida Department of Revenue does not anticipate finalizing its projections until mid-June to late July.

Two Public Hearings are conducted to obtain further community comments. At the first Public Hearing (Wednesday, September 11th @ 6:00PM) for tentative millage and budget adoption, it is planned that the Town will continue to take advantage of the Broward Property Appraisers twenty-day notice guarantee pertaining to our non-advallorem Fire Protection and Solid Waste special assessments and also adopt a final resolution pertaining to rate adjustments, as deemed necessary by our independent rate consultants. Please note that the first Public Hearing cannot be held prior to September 11th nor later than September 14th, 2019 per Florida Statutes.

In conformity with last year's budget calendar, the final budget and millage rate be adopted by ordinance at a second Public Hearing on Thursday, September 26 @ 6:00pm (one hour prior to the September regular Council meeting). At this meeting the budget document becomes the agreed resource allocation plan for the coming fiscal year. A summary budget document is adopted by the Town Council to provide appropriations to fund the budget allocation plan.

Staff Contact:

Martin Sherwood, Town Financial Administrator
Richard Strum, Controller

ATTACHMENTS:

Description	Upload Date	Type
FY 2019-2020 Proposed Budget Calendar-Attachment A	2/5/2019	Resolution

TOWN OF SOUTHWEST RANCHES, FL
Council Proposed Budget Calendar for FY 2019-2020

Monday, February 04, 2019	Town Financial Administrator meets with Town Administrator for General Direction
Tuesday, February 05, 2019	Budget Kick-Off with Department Heads and Staff/Advisory Bd Liaisons
Thursday, February 28, 2019	Memo to Town Council- Proposed Budget Calendar for FY 2019-2020 presented at regular Council meeting
March 11th to May 20th, 2019	Town Administrator and Town Financial Administrator to meet individually with Town Council members to obtain policy direction
Monday, March 11, 2019	Department Descriptions, Accomplishments, Goals and Objectives Due from Department Heads
Monday, March 18, 2019	Departmental and Advisory Boards Capital Improvement (> \$24,999) and Program Modification Requests Due
Monday, March 25, 2019	Departmental and Advisory Boards operating and capital outlay (\$1,000 but < \$25,000) requests and justification due
Friday, April 05, 2019	Department Revenue Estimates Due from Department Heads
Thursday, April 18, 2019	Departmental Meetings (9:30-11:00 am; 1:00-2:30PM; 3:00-4:30PM)
Friday, April 19, 2019	Departmental Meetings (9:30-11:00 am; 1:00-2:30PM; 3:00-4:30PM)
Monday, April 22, 2019	Departmental Meetings (9:30-11:00 am; 1:00-2:30PM; 3:00-4:30PM)
Friday, May 17, 2019	Town Financial Administrator meets with Town Administrator and Town Attorney (preliminary condition assessment/recommendations/modifications) - post council direction
Monday, May 20, 2019 to ongoing	Draft Proposed FY 2019-2020 Departmental Sectional worksheets Distributed
Saturday, June 01, 2019	Estimated Tax roll information available from Property Appraiser
Monday, June 03, 2019	Comments/Corrections Due on Draft-Administrators/Attorney/Departments
Monday, July 01, 2019	Certified Taxable Values Received from Property Appraiser
Friday, July 12, 2019	Final Proposed Budget finished, printing begins & distribution commences
Thursday, July 25, 2019	Preliminary Millage Rate and Initial FY 2019-2020 Fire Protection and Solid Waste (SW) special assessment Adoption at July Regular Council Meeting (all via resolutions)
Tuesday, July 30, 2019	TBD: First Budget Hearing for Broward County School Board
Friday, August 09, 2019	TBD: Deadline to send the Preliminary Millage Rate and Initial FY 2019-2020 Fire Protection and SW special assessment to the Broward County Property Appraiser Office and the Broward County Treasury Division
Tuesday, August 20, 2019	Budget Workshop on Proposed Budget (7 PM)- Mayor and Town Council (Community Invited)
On or prior to August 22, 2019	TBD: Town advertises its non-ad valorem Special Assessments. Advertisement must run at least 20 days prior to final public hearing for assessment adoption
Thursday, August 22, 2019	August regular Council Meeting
On or prior to August 23, 2019	TBD: Notice for First Public Hearing through TRIM notice sent by Property Appraisers' office
Wednesday, September 04, 2019	TBD: Second Budget Hearing for Broward County School Board
Wednesday, September 11, 2019	TBD: First Public Hearing for Tentative Millage and Budget Adoption introduced for FY 2019-2020 (via ordinances). Final Fire Protection and SW special assessment Adoption (via resolutions) @ 6:00PM. September Regular Council meeting @ 7:30PM
Thursday, September 12, 2019	TBD: First Budget Hearing for Broward County Government
Friday, September 13, 2019	Deadline to send the adopted Final Fire Protection and SW special assessment to the Broward County Property Appraiser Office and the Broward County Treasury Division
Tuesday, September 17, 2019	Deadline for Newspaper advertisement submission
Saturday, September 21, 2019	First Date: advertisement can run for second public hearing
Tuesday, September 24, 2019	Last Date: advertisement can run for second public hearing
Tuesday, September 24, 2019	TBD: Second Budget Hearing for Broward County Government
Thursday, September 26, 2019	Second Public Hearing for Final Millage and Budget Adoption (via ordinances) @ 6:00 PM. September Regular Council meeting @ 7:00PM

REGULAR MEETING MINUTES OF THE TOWN COUNCIL
Southwest Ranches, Florida

Thursday 7:00 PM

November 15, 2018

13400 Griffin Road

Present:

Mayor Doug McKay

Vice Mayor Gary Jablonski

Council Member Bob Hartmann

Council Member Freddy Fisikelli

Council Member Denise Schroeder

Andrew Berns, Town Administrator

Russell Muñiz, Assistant Town Administrator/Town Clerk

Martin D. Sherwood, Town Financial Administrator

Keith Poliakoff, Town Attorney

Regular Meeting of the Town Council of Southwest Ranches was held at 13400 Griffin Road in the Southwest Ranches Council Chambers. The meeting, having been properly noticed, was called to order by Mayor McKay at 7:03 PM. Attendance was noted by roll call and was followed by the Pledge of Allegiance.

In honor of Veterans Day, a ceremony honoring Veterans was held. The Boy Scouts from Troop 160 presented the colors. Madison Sullivan led the meeting with the National Anthem. At the conclusion of the ceremony, all Veterans in attendance were asked to stand and state their name, where and when they served. A special pin to acknowledge their military services and sacrifices was given to each Veteran.

Selection of Vice Mayor

- 3.** A RESOLUTION OF THE TOWN COUNCIL OF THE TOWN OF SOUTHWEST RANCHES, FLORIDA, APPOINTING COUNCIL MEMBER _____ TO SERVE AS THE NEW VICE MAYOR FOR THE TOWN OF SOUTHWEST RANCHES; AND PROVIDING AN EFFECTIVE DATE.

The following motion was made by Council Member Schroeder, seconded by Council Member Hartmann and passed by a 5-0 roll call vote. The vote was as follows: Council Members Hartmann, Schroeder, Fisikelli, Vice Mayor Jablonski, and Mayor McKay voting Yes.

MOTION: TO APPROVE THE RESOLUTION AND APPOINT GARY JABLONSKI AS VICE MAYOR.

4. Veteran's Day Recognition

The Boy Scouts from Troop 224 and Pack 160 individually recited stanzas from a Veterans Day poem in honor of Veterans Day and provided flag pins to the public.

5. Presentation - Eagle Scout Project

Eagle Scout Jonathan DiPasquale explained his project proposal on building bat houses. Mayor McKay pledged \$100.

6. Public Comment

The following members of the public addressed the Town Council: David Kuczenski, Steve Breitkreuz, Newell Hollingsworth, Robert Parker, and Mary Gay Chaples.

7. Board Reports

George Morris, Chair of the Comprehensive Planning Board (CPAB) provided an update on the Nursery Operations ordinance.

Mary Gay Chaples, Chair of the Recreation, Forestry, and Natural Resources Advisory Board (Parks & Rec) announced that the Car Show & Chili Festival will be held on Saturday, November 17th, and urged residents to attend. She explained that all of the proceeds will benefit the trees at Southwest Meadows Sanctuary and Frontier Trails Park that are in need of care. She recognized Aster Knight, Chair of the Southwest Ranches Parks Foundation and George Morris, Chair of the Comprehensive Planning Board for all their efforts in the completion of the Rolling Oaks Barn.

8. Council Member Comments

Mayor McKay recognized Aster Knight, Chair of the Southwest Ranches Parks Foundation with a proclamation which was read into the record. Aster Knight accepted the proclamation and thanked everyone. He said that even though he no longer resides in Southwest Ranches, his heart will always be here.

Council Member Schroeder also mentioned that Broward County issued a proclamation to Aster Knight announcing "Aster Knight Day" on his 80th birthday.

Vice Mayor Jablonski thanked everyone who attended the meeting, especially the Veterans that were present. He also recognized Aster Knight for his years of service to the Town. Vice Mayor Jablonski advised of upcoming events including the Car Show & Chili Festival on Nov. 17th, the Fun Horse Show on Dec. 8th, the Broward County Property Appraiser on Dec. 6th, and the Flow Mobile on Dec. 27th. He expressed gratitude for the Town's support in allowing him to be Vice Mayor. He pledged that he would work very hard for the next four years.

Council Member Fisikelli thanked Steve Breitkreuz for his leadership and all the years he served the Town.

Council Member Schroeder reported that on behalf of the Metropolitan Planning Organization (MPO), the Park & Ride has been removed from the plan. Also, the project to widen the roadway expansion was turned down. She thanked everyone for coming out, especially the Veterans and the Boy Scouts. Council Member Schroeder spoke of a card that she received recently in the mail which contained false information. She suggested to everyone that before sharing any information in Town, to make sure the information is correct and to consult with Town Attorney Poliakoff or Town Administrator Berns. Lastly, she congratulated Council Member Bob Hartmann on his election victory and she was looking forward to working with him in the future.

Council Member Hartmann thanked all the Veterans for their service.

Mayor McKay also thanked the Veterans for their service. He also wished to congratulate Bob Hartmann on his election victory, and thanked everyone for coming.

9. Legal Comments

Town Attorney Poliakoff thanked all of the Veterans for their service. He wished Aster Knight a Happy Birthday and recognized everything that he has done for the Town. He advised of a meeting with Pembroke Park which was held in reference to West Park's intent to de-annex portions of their municipality. He also advised that the Code Enforcement Hearing will take place on November 19th as a result of the elections. Lastly, Town Attorney Poliakoff congratulated Vice Mayor Jablonski and Council Member Hartmann on their election victories.

10. Administration Comments

Town Administrator Berns also thanked the Veterans for their service and all the Boy Scouts for making the Veterans Day Commemoration even more special. He congratulated Vice Mayor Jablonski and Council Member Hartmann on their election victories. Town Administrator Berns wished everyone a Happy Thanksgiving, and thanked everyone for coming out.

Resolutions

- 11.** A RESOLUTION OF THE TOWN COUNCIL OF THE TOWN OF SOUTHWEST RANCHES, FLORIDA, APPROVING A CONTINUING SERVICES AGREEMENT WITH WEEKLEY ASPHALT PAVING, INC. FOR ROADWAY REPAIR AND TRAFFIC SIGN MAINTENANCE SERVICES; AUTHORIZING THE MAYOR, TOWN ADMINISTRATOR, AND TOWN ATTORNEY TO ENTER INTO AN AGREEMENT; AND PROVING AN EFFECTIVE DATE.

The following motion was made by Vice Mayor Jablonski, seconded by Council Member Schroeder and passed by a 5-0 roll call vote. The vote was as follows: Council Members Hartmann, Fisikelli, Schroeder, Vice Mayor Jablonski, and Mayor McKay voting Yes.

MOTION: TO APPROVE THE RESOLUTION.

- 12.** A RESOLUTION OF THE TOWN COUNCIL OF THE TOWN OF SOUTHWEST RANCHES, FLORIDA, APPROVING A YEAR END BUDGET ADJUSTMENT FOR THE FISCAL YEAR 2017-2018 BUDGET; AND PROVIDING FOR AN EFFECTIVE DATE.

The following motion was made by Council Member Schroeder, seconded by Council Member Hartmann and passed by a 5-0 roll call vote. The vote was as follows: Council Members Hartmann, Fisikelli, Schroeder, Vice Mayor Jablonski, and Mayor McKay voting Yes.

MOTION: TO APPROVE THE RESOLUTION.

- 13.** A RESOLUTION OF THE TOWN COUNCIL OF THE TOWN OF SOUTHWEST RANCHES, FLORIDA, APPROVING THE SECOND AMENDMENT TO THE SETTLEMENT AGREEMENT WITH BROWARD COUNTY FOR THE LITIGATION STYLED CITY OF SUNRISE ET. AL. VS. BROWARD COUNTY; AND PROVIDING FOR AN EFFECTIVE DATE.

The following motion was made by Council Member Schroeder, seconded by Vice Mayor Jablonski, and passed by a 5-0 roll call vote. The vote was as follows: Council Members Hartmann, Schroeder, Fisikelli, Vice Mayor Jablonski and Mayor McKay voting Yes.

MOTION: TO APPROVE THE RESOLUTION.

Discussion

14. Potential Rezoning of Flamingo Road Corridor

Mayor McKay discussed the possibility of potential rezoning of the Flamingo Road Corridor. Although many residents in attendance voiced their displeasure concerning the potential rezoning of the Flamingo Road Corridor, a few were in favor of the rezoning.

15. Approval of Minutes

- a. September 27, 2018 – Sole Purpose Meeting
- b. September 27, 2018 – Second Budget Hearing
- c. October 11, 2018 – Regular Meeting

The following motion was made by Vice Mayor Jablonski, seconded by Council Member Schroeder and passed by a 5-0 roll call vote. The vote was as follows: Council Members Hartmann, Schroeder, Fisikelli, Vice Mayor Jablonski and Mayor McKay voting Yes.

MOTION: TO APPROVE THE MINUTES.

16. Adjournment - Meeting was adjourned at 9:28 PM.

Respectfully submitted:

Ivette Solera, Deputy Town Clerk, CMC

*Adopted by the Town Council on
this 28th day of February, 2019.*

Doug McKay, Mayor

PURSUANT TO FLORIDA STATUTES 286.0105, THE TOWN HEREBY ADVISES THE PUBLIC THAT IF A PERSON DECIDES TO APPEAL ANY DECISION MADE BY THIS COUNCIL WITH RESPECT TO ANY MATTER CONSIDERED AT ITS MEETING OR HEARING, HE OR SHE WILL NEED A RECORD OF THE PROCEEDINGS, AND THAT FOR SUCH PURPOSE, THE AFFECTED PERSON MAY NEED TO ENSURE THAT VERBATIM RECORD OF THE PROCEEDING IS MADE, WHICH RECORD INCLUDES THE TESTIMONY AND EVIDENCE UPON WHICH THE APPEAL IS TO BE BASED THIS NOTICE

DOES NOT CONSTITUTE CONSENT BY THE TOWN FOR THE INTRODUCTION OR ADMISSION OF OTHERWISE INADMISSIBLE OR IRRELEVANT EVIDENCE, NOR DOES IT AUTHORIZE CHALLENGES OR APPEALS NOT OTHERWISE ALLOWED BY LAW.

REGULAR MEETING MINUTES OF THE TOWN COUNCIL
Southwest Ranches, Florida

Thursday 7:00 PM

January 24, 2019

13400 Griffin Road

Present:

Mayor Doug McKay

Vice Mayor Gary Jablonski

Council Member Bob Hartmann

Council Member Freddy Fisikelli

Council Member Denise Schroeder

Andrew Berns, Town Administrator

Russell Muñiz, Assistant Town Administrator/Town Clerk

Martin D. Sherwood, Town Financial Administrator

Keith Poliakoff, Town Attorney

Regular Meeting of the Town Council of Southwest Ranches was held at 13400 Griffin Road in the Southwest Ranches Council Chambers. The meeting, having been properly noticed, was called to order by Mayor McKay at 7:04 PM. Attendance was noted by roll call and was followed by the Pledge of Allegiance.

3. Recognition of Sikh Society of Florida for Military Heroes Support Foundation Holiday Drive Donation

4. Recognition of 2019 Mr. & Miss Southwest Ranches Pageant Winners

5. Public Comment

The following members of the public addressed the Town Council: George Cailis, David Sears, Gay Chaples, Newell Hollingsworth, and David Kuczenski.

6. Board Reports

George Morris, Vice Chair of the Comprehensive Planning Board asked Council to extend the date of the Nursery Ordinance Project Review to the meeting scheduled for March 28, 2019.

The following motion was made by Council Member Hartmann, seconded by Mayor McKay, and passed by a 4-0 roll call vote. The vote was as follows: Council Members Hartmann, Schroeder, Vice Mayor Jablonski, and Mayor McKay voting Yes.

MOTION: TO EXTEND THE DATE NURSERY ORDINANCE PROJECT REVIEW TO MARCH 28, 2019 MEETING.

Gay Chaples, Chair of the Parks Board expressed the need for funding the parks which need work, especially the ones out in the west area of Town.

Also, there is an issue with flooding at the Rolling Oaks Park due to lack of drainage.

7. Council Member Comments

Council Member Schroeder welcomed all the new advisory board members that have joined this year. She also welcomed Jeff Hobales, our new detective to the Town. In addition, Council

Member Schroeder expressed her condolences to the Fisikelli, Breitzkreuz, and Whim families for their recent losses.

Vice Mayor Jablonski reported that the South Florida Water Management District will be removing many Ficus trees west of I-75 by the C-11 canal. Also, he pointed out that there is an error on our February Town Newsletter about the Hazardous Household Waste event. The event is scheduled for March 9th, not February 9th. Vice Mayor Jablonski advised of upcoming events such as the Garage Sale on February 16th, Hawkes Bluff Food Truck Event on January 25th, and the DMV Flow Mobile on February 28th.

He congratulated the pageant winners. He especially gave kudos to Kathy Sullivan, Chairperson of the Schools and Education Advisory Board, for the successful Mr. & Miss Southwest Ranches Pageant. Vice Mayor Jablonski's thoughts and prayers go out to the Fisikelli and the Breitzkreuz families for their losses.

Council Member Hartmann requested a moment of silence for the three persons who recently passed. Next, he spoke about the Ring Video Doorbell which posts robberies and burglaries in the neighborhood. He wanted to make everybody aware that burglars are looking for car doors to open. He advised that if anyone sees something, say something and call the police.

Also, he shared that one of the main topics being discussed at many of the Town's Homeowners Association meetings is the problem with speeding drivers. He welcomed Detective Jeff Hobales to the Town. Lastly, Council Member Hartmann stated that he enjoyed attending the Mr. & Miss Southwest Ranches Pageant.

Mayor McKay expressed condolences on the passing of Sarah Fisikelli and all the others previously mentioned. He was one of the judges at the pageant, and had a great time. The Mayor said it was fun to watch, and is looking forward to it again next year. Lastly, he invited everyone to attend the Food Truck Fundraiser on Friday, January 25th.

8. Legal Comments

Town Attorney Poliakoff condolences to the Fisikelli, Breitzkreuz, and Stuart families. He congratulated Kathy Sullivan in her efforts to continue awarding scholarships to our Town's young residents. He mentioned that his wife's car was burglarized, but the Ring Video Doorbell captured the robber trying to smash the window in order to get into the car. He urged everyone to call Davie Police to report anything that may seem suspicious.

Town Attorney Poliakoff explained to Town Council and residents the reason why the Town is being sued. He attended the first hearing in the Palomino Right-of Way Case. He explained that Palomino Drive is a unique street in Sunshine Ranches because the county created it with a swale and a horse trail only on one side of the road. After conducting property research on the side of the swale, a developer built two homes on the property. Three years after building the homes, the county as a condition precedent to issuing the certificate of occupancy, said that the right of way had to be dedicated in order to finish the swale. Since the developer no longer owned the

property, the Statute of Limitations Law says that if a deed has been conveyed illegally or improperly and it is not challenged in twenty years, it can no longer be challenged.

The owner of the property adjacent to Mr. McBride obtained a building permit for a wall using a fraudulent survey indicating that they owned the swale. When the Town discovered the impropriety they advised the property owner that if they should ever need a building permit in the future they will need to move the wall back onto their property. Before purchasing the property, Mr. McBride met with Mayor McKay, who advised him of putting the fence on his property, and not on the right of way.

A hurricane blew the whole fence down. In an effort to put up a new fence, Mr. McBride submitted an after the fact survey for a new fence. Code Enforcement Director, Robert Solera denied the permit because the survey showed that the swale did not belong to Mr. McBride, but to the Town.

McBride is suing the Town for alleged abuse of power, because the Town is asking him to put the fence out of the swale and back onto his property. At the hearing, the judge recommended to go to mediation for thirty days to discuss the issue. As a result, the judge eluded to the fact that there needed to be a different cause of action file to confirm the title ownership of the property. Therefore, the Town will have to file a quiet Title Action to get a summary judgement from the judge to confirm that the Town owns the property. Hopefully, this will resolve the issue once and for all.

9. Administration Comments

Town Administrator Berns added his condolences to the Fisikelli family. In response to Vice Mayor Jablonski and Council Member Hartmann's previous comments about the tree trimmings, he informed that the South Florida Water Management is following a mandate from the State that involves removing all trees growing out of the canal banks. Only the trees that are back from the canal bank will be left, but trees on the canal banks will be taken down. They are starting from US-27 West all the way to 441 working towards the East.

In addition, he announced that there are two items on the agenda that will be postponed for the next Town Council Meeting. The first item postponed is an award for construction improvement, however the insurance has not yet been resolved. Town Financial Administrator Sherwood is currently working on it. The second item postponed is the annual review of Charter Officials, because Town Administrator Berns feels that a full Council be present in order to participate in the discussion.

Also, Town Administrator Berns explained that the noise complaints recently made by some residents was addressed at a previous meeting with Acting Chief Dale Engle from Davie Police Department in an effort to come up with creative steps in order to correct the problem. In addition, Town Administrator Berns explained that the concern about speeding drivers has been an issue for an extended period of time, especially with hot spots throughout Town. However, he has made the Acting Chief Engle and Service Aide Tommy Squarini aware of the issue and are

working together to come up with a solution. He also welcomed Detective Jeff Hobales to the Town family.

Lastly, Town Administrator Berns mentioned the previous conversation he had with Town Attorney Poliakoff about the potential expansion proliferation of the 5G Cell Service. He advised Town Attorney Poliakoff that Council is supportive if a legal class action litigation should be needed. The Town Attorney replied to Town Administrator Berns that he will look into this issue and come back at a later meeting with the costs.

Ordinance – 2nd Reading

10. AN ORDINANCE OF THE TOWN OF SOUTHWEST RANCHES, FLORIDA, ADOPTING THE FIVE-YEAR SCHEDULE OF CAPITAL IMPROVEMENTS FOR FISCAL YEARS 2019-2023 PURSUANT TO CHAPTER 163, FLORIDA STATUTES; PROVIDING FOR CONFLICT; PROVIDING FOR SEVERABILITY; AND PROVIDING FOR AN EFFECTIVE DATE. {APPROVED ON FIRST READING – DECEMBER 13, 2018}

The following motion was made by Vice Mayor Jablonski, seconded by Council Member Schroeder, and passed by a 4-0 roll call vote. The vote was as follows: Council Members Hartmann, Schroeder, Vice Mayor Jablonski, and Mayor McKay voting Yes.

MOTION: TO APPROVE THE ORDINANCE.

Resolutions

11. A RESOLUTION OF THE TOWN COUNCIL OF THE TOWN OF SOUTHWEST RANCHES, FLORIDA, ASSURING THE STATE OF FLORIDA DIVISION OF EMERGENCY MANAGEMENT, AND THE DEPARTMENT OF HOMELAND SECURITY'S FEDERAL EMERGENCY MANAGEMENT AGENCY (FEMA) WITH EFFECTIVE ENFORCEMENT, TO IMPLEMENT AN NFIP-COMPLIANT PROGRAM; VESTING THE TOWN'S FLOODPLAIN ADMINISTRATOR WITH THE RESPONSIBILITY, AUTHORITY, AND MEANS TO IMPLEMENT PERFORMANCE MEASURES TO ACHIEVE ELIGIBILITY FOR THE COMMUNITY RATING SYSTEM; AND PROVIDING AN EFFECTIVE DATE.

The following motion was made by Vice Mayor Jablonski seconded by Council Member Schroeder and passed by a 4-0 roll call vote. The vote was as follows: Council Members Hartmann, Schroeder, Vice Mayor Jablonski, and Mayor McKay voting Yes.

MOTION: TO APPROVE THE RESOLUTION.

12. A RESOLUTION OF THE TOWN COUNCIL OF THE TOWN OF SOUTHWEST RANCHES, FLORIDA, APPROVING A PURCHASE ORDER BY PIGGYBACKING OFF OF THE CITY OF FORT LAUDERDALE'S AGREEMENT WITH E-SCIENCES INCORPORATED IN THE AMOUNT OF ELEVEN THOUSAND DOLLARS AND ZERO CENTS (\$11,000.00) FOR ENVIRONMENTAL PERMITTING SERVICES FOR THE BACTERIAL POLLUTION CONTROL PLAN IN ACCORDANCE WITH THE TOWN'S FLORIDA DEPARTMENT OF ENVIRONMENTAL PROTECTION (FDEP) NATIONAL POLLUTANT DISCHARGE ELIMINATION SYSTEM (NPDES) MUNICIPAL SEPARATE STORM SEWER SYSTEM (MS4)

PERMIT NUMBER FLS000016-004; AUTHORIZING THE TOWN ADMINISTRATOR TO EXECUTE THE PURCHASE ORDER; AND PROVIDING AN EFFECTIVE DATE.

The following motion was made by Council Member Schroeder, seconded by Vice Mayor Jablonski, and passed by a 4-0 roll call vote. The vote was as follows: Council Members Hartmann, Schroeder, Vice Mayor Jablonski and Mayor McKay voting Yes.

MOTION: TO APPROVE THE RESOLUTION.

13. A RESOLUTION OF THE TOWN COUNCIL OF THE TOWN OF SOUTHWEST RANCHES, FLORIDA, APPROVING A PURCHASE ORDER WITH CRAIG A. SMITH AND ASSOCIATES IN THE AMOUNT OF SEVENTY-SEVEN THOUSAND TEN DOLLARS AND ZERO CENTS (\$77,010.00) FOR ENGINEERING AND DESIGN SERVICES, BIDDING ASSISTANCE, AND CONSTRUCTION PHASE SERVICES FOR THE FLORIDA DEPARTMENT OF ENVIRONMENTAL PROTECTION FUNDED GREEN MEADOWS DRAINAGE IMPROVEMENTS; AUTHORIZING THE TOWN ADMINISTRATOR TO EXECUTE THE PURCHASE ORDER; AND PROVIDING AN EFFECTIVE DATE.

The following motion was made by Council Member Schroeder, seconded by Vice Mayor Jablonski, and passed by a 4-0 roll call vote. The vote was as follows: Council Members Hartmann, Schroeder, Vice Mayor Jablonski and Mayor McKay voting Yes.

MOTION: TO EXCUSE COUNCIL MEMBER FISIKELLI'S ABSENCE.

14. A RESOLUTION OF THE TOWN COUNCIL OF THE TOWN OF SOUTHWEST RANCHES, FLORIDA, APPROVING AN AGREEMENT IN THE AMOUNT OF FIFTY-NINE THOUSAND THREE HUNDRED TWENTY-FOUR DOLLARS AND NINETY CENTS (\$59,324.90) WITH PHI CONSTRUCTION, INC. TO CONSTRUCT IMPROVEMENTS IN THE FRONTIER TRAILS CONSERVATION AREA; AUTHORIZING THE MAYOR, TOWN ADMINISTRATOR, AND TOWN ATTORNEY TO ENTER INTO AN AGREEMENT; APPROVING A BUDGET AMENDMENT TO THE FISCAL YEAR 2018/2019 BUDGET FOR THE FRONTIER TRAILS PARK IMPROVEMENT; AND PROVIDING AN EFFECTIVE DATE.

The following motion was made by Vice Mayor Jablonski, seconded by Council Member Schroeder, and passed by a 4-0 roll call vote. The vote was as follows: Council Members Hartmann, Schroeder, Vice Mayor Jablonski and Mayor McKay voting Yes.

MOTION: TO EXTEND THE NURSERY ORDINANCE.

Discussion

- 15.** Annual Review of Charter Officials
Item was moved to February 28, 2019.
- 16.** Approval of Minutes
a. December 13, 2018 – Regular Meeting

The following motion was made by Council Member Hartmann, seconded by Council Member Schroeder and passed by a 4-0 roll call vote. The vote was as follows: Council Members Hartmann, Schroeder, Vice Mayor Jablonski and Mayor McKay voting Yes.

MOTION: TO APPROVE THE MINUTES.

17. Adjournment - Meeting was adjourned at 8:45 PM.

Respectfully submitted:

Ivette Solera, Deputy Town Clerk, CMC

*Adopted by the Town Council on
this 28th day of February, 2019.*

Doug McKay, Mayor

PURSUANT TO FLORIDA STATUTES 286.0105, THE TOWN HEREBY ADVISES THE PUBLIC THAT IF A PERSON DECIDES TO APPEAL ANY DECISION MADE BY THIS COUNCIL WITH RESPECT TO ANY MATTER CONSIDERED AT ITS MEETING OR HEARING, HE OR SHE WILL NEED A RECORD OF THE PROCEEDINGS, AND THAT FOR SUCH PURPOSE, THE AFFECTED PERSON MAY NEED TO ENSURE THAT VERBATIM RECORD OF THE PROCEEDING IS MADE, WHICH RECORD INCLUDES THE TESTIMONY AND EVIDENCE UPON WHICH THE APPEAL IS TO BE BASED THIS NOTICE DOES NOT CONSTITUTE CONSENT BY THE TOWN FOR THE INTRODUCTION OR ADMISSION OF OTHERWISE INADMISSIBLE OR IRRELEVANT EVIDENCE, NOR DOES IT AUTHORIZE CHALLENGES OR APPEALS NOT OTHERWISE ALLOWED BY LAW.