

RESOLUTION NO. 2010 - 071

A RESOLUTION OF THE TOWN COUNCIL OF THE TOWN OF SOUTHWEST RANCHES, FLORIDA APPROVING AN AWARD OF BID TO GIRALT ENTERPRISES, INC., FOR FORTY-FOUR THOUSAND EIGHT HUNDRED DOLLARS (\$44,800.00) TO FABRICATE ALUMINUM SLUICE GATES; AUTHORIZING THE TOWN ADMINISTRATOR TO ISSUE A PURCHASE ORDER; AND PROVIDING AN EFFECTIVE DATE.

WHEREAS, on May 6, 2010, pursuant to Resolution No. 2010-059, the Town Council approved an agreement with South Florida Water Management District accepting a \$205,200 grant to construct additional water control structures and sediment sumps along with conducting water quality sampling; and

WHEREAS, the Town Council believes that it is in the best interest of the Town to contract with a professional firm to perform the services required by the grant; and

WHEREAS, on June 9, 2010, the Town advertised an Invitation for Bid; and

WHEREAS, on June 14, 2010, the Town received one (1) bid in response to the advertisement; and

WHEREAS, Giralt Enterprises, Inc., has provided the lowest-priced responsive and responsible bid; and

WHEREAS, the Town of Southwest Ranches desires to award the bid to Giralt Enterprises, Inc., under the terms and conditions set forth in the Invitation For Bid attached hereto as Exhibit "A."

NOW, THEREFORE, BE IT RESOLVED by the Town Council of the Town of Southwest Ranches, Florida:

Section 1. The above-referenced recitals are true and correct and are incorporated herein by reference.

Section 2. The Town Council hereby authorizes the Town Administrator to issue a Purchase Order under the terms and conditions set forth in Exhibit "B" attached hereto.

Section 3. That this Resolution shall become effective immediately upon its adoption.

PASSED AND ADOPTED by the Town Council of the Town of Southwest Ranches, Florida, this 17th day of June, 2010 on a motion by Council Member McKay and seconded by Council Member Breitkreuz.

Nelson	<u>AYE</u>
Knight	<u>AYE</u>
Breitkreuz	<u>AYE</u>
Fisikelli	<u>AYE</u>
McKay	<u>AYE</u>

Ayes	<u>5</u>
Nays	<u>0</u>
Absent	<u>0</u>
Abstaining	<u>0</u>

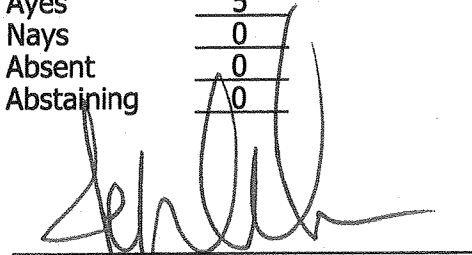

Jeff Nelson, Mayor

Attest: 

Debra Doré-Thomas, CMC, Town Clerk

Approved as to Form and Correctness:



Keith M. Poliakoff, Town Attorney
ACTIVE: 3009812_1

Resolution 2010-071 Exhibit A

TOWN OF SOUTHWEST RANCHES
BROWARD COUNTY, FLORIDA

INVITATION FOR BID (IFB)
FABRICATION OF ALUMINUM SLUICE GATES
10-013

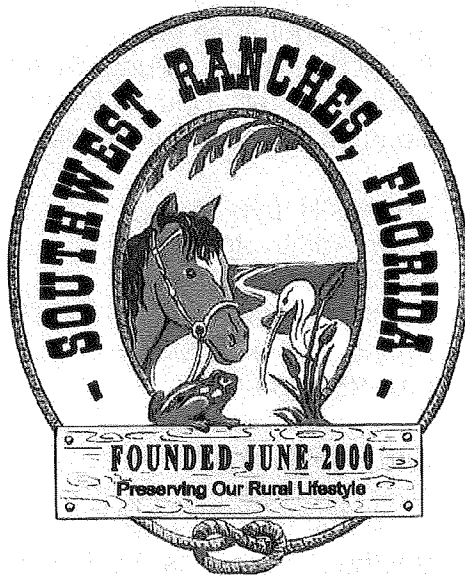

Opening Date/Time: Monday, June 14, 2010 / 11:00 A.M.
Submit To: Juanita Romance, Deputy Town Clerk
6589 SW 160 Avenue
Southwest Ranches, FL 33331

Date: June 9, 2010

TOWN OF SOUTHWEST RANCHES, FLORIDA
"ALUMINUM SLUICE GATES" BID #: # 10-013

CONTRACT DATA

Contract Title: "Bid: # 10-013 Fabrication of Aluminum Sluice Gates"

Contract Number: Town Bid # 10-013

Contract Address: 6589 SW 160th Avenue
Southwest Ranches, FL 33331

Contract Owner: Town of Southwest Ranches

Town Council: Jeff Nelson, Mayor
Aster Knight, Vice Mayor
Steve Breitkreuz, Council Member
Freddy Fisikelli, Council Member
Doug McKay, Council Member

Owner's Representative: Charles H. Lynn
Town Administrator
6589 SW 160th Avenue
Southwest Ranches, FL 33331
Phone: 954-434-0008
Fax: 954-434-1490

Contract Manager: Carl Huntsberger
Town Engineer
6589 SW 160th Avenue
Southwest Ranches, FL 33331
Phone: 954-434-0008 ext. 201
Fax: 954-434-1490

Table of Contents

INVITATION FOR BID	4
INSTRUCTIONS TO BIDDERS	5
BID PROPOSAL FORM	10
GATE DETAILS	12
TECHNICAL SPECIFICATIONS	13

TOWN OF SOUTHWEST RANCHES, FLORIDA
"ALUMINUM SLUICE GATES" BID #: # 10-013

TOWN OF SOUTHWEST RANCHES
PUBLIC NOTICE OF INVITATION FOR BID (IFB)

ALL INTERESTED PARTIES:

The Town of Southwest Ranches, Florida, hereinafter referred to as TOWN, will receive sealed bids and any other information relative to the experience, expertise or proficiency of the Bidder, at the office of Juanita Romance, Deputy Town Clerk, Town of Southwest Ranches, 6589 SW 160th Avenue, Southwest Ranches, Florida, 33331 954-434-0008, for furnishing the services described below:

"ALUMINUM SLUICE GATES" BID #: # 10-013

Bids clearly marked "**Bid: # 10-013 Fabrication of Aluminum Sluice Gates**" must be received by the Deputy Town Clerk, either by mail or hand delivery, no later than 11:00 a.m. local time on **Monday, June 14, 2010**. A public opening will take place at 11:00 a.m. in the TOWN's main conference room located at Town Hall on the same date. Facsimile submittals will not be accepted. Any Bid received after 11:00 a.m. local time on said date will not be accepted under any circumstances. Any uncertainty regarding the time a Bid is received will be resolved against the Bidder.

The bids will be opened publicly at 11:00 AM by Town Staff. TOWN reserves the right to reject any or all bids, to waive any or all non-material irregularities and technicalities to re-advertise for bids, with or without changes in the scope of work, or take any other such actions that may be deemed to be in the best interests of the TOWN.

No bidder may withdraw his bid within ninety (90) days after the actual date of the opening.

All bid responses must conform to the "Information to Bidders" section of the bid documents and must include a properly executed Bid Form.

TOWN OF SOUTHWEST RANCHES, FLORIDA
"ALUMINUM SLUICE GATES" BID #: # 10-013

INSTRUCTIONS TO BIDDERS

BIDS: Bids will be received for furnishing all transportation, labor, materials, tools, supplies, plant, equipment and machinery necessary, and performing all operations required for the completion of the work herein specified and as shown on the drawings.

DEFINITION OF TERMS: Where the following terms or their pronouns occur herein, the intent and meaning shall be as follows;

Engineer: The term Engineer refers to Higgins Engineering, Inc. or other engineering firm as may be designated by the Town.

Bidder: Any person, firm or corporation submitting a bid for the work covered by these specifications, or his duly authorized representative.

Contractor: The person, persons, firm or corporation with whom the Agreement has been executed by the Town.

Manufacturer or Supplier: Any person, firm or corporation other than the Contractor, supplying labor, material or equipment for the work herein specified.

DELIVERY OF BIDS: Bids shall be delivered by the time and to the place stipulated in the Invitation for Bid. It is the sole responsibility of the Bidder to see that his Bid is received in proper time. Any bid received after the scheduled closing time for receipt of bids will be returned to the Bidder unopened.

One original, three (3) copies and 1 CD of the entire Bid should be submitted to the Town of Southwest Ranches at the office of Juanita Romance, Deputy Town Clerk, Town Hall, 6589 SW 160th Avenue, Southwest Ranches, Florida 33331 (954)-434-0008.

WITHDRAWL OF BIDS: Any Bidder may withdraw its bid prior to the opening, by providing written notice to the Town. No bidder may withdraw his bid for ninety (90) days after the bid opening.

TIME OF AWARD: The Town reserves the right to hold all bids for a period not to exceed 90 days after the date of receipt of the bid.

POSTPONEMENT OF DATE FOR PRESENTING AND OPENING BIDS: The Town reserves the right to postpone the date for opening of Bids and will give written notice of any such postponement to each party receiving a set of Documents.

TOWN OF SOUTHWEST RANCHES, FLORIDA
"ALUMINUM SLUICE GATES" BID #: # 10-013

BID FORMS: The bidder shall submit his bid in duplicate on the forms, or an exact copy of the forms furnished herewith. The blank spaces shall be filled in correctly for each item and for every item for which a bid is tendered. The bidder shall state the price, typewritten or written in ink, for which he proposes to do each item of work called for.

SIGNATURE ON BID: Anyone signing the Bid as an agent shall file with the Bid, legal evidence of his authority to do so. The bid shall be signed by an individual who has full authority to bind the bidder and offer to perform the work for the price set forth in the bid form.

FAMILIARITY WITH LAWS: The bidder is assumed to be familiar with all federal, state and local laws, ordinances, rules and regulations that may in any manner affect the work. The failure to familiarize himself with applicable laws will in no way relieve him from responsibility.

EXAMINATION OF PLANS AND SPECIFICATIONS: The bidder is required, before submitting his bid, to familiarize himself with the nature and extent of the work and any local conditions that may in any manner affect the work to be done and the equipment, materials and labor required. He is also required to examine carefully the plans, specifications, form of agreement and form of performance and payment bond and to inform himself thoroughly regarding any and all conditions and requirements that may in any manner affect the work to be performed under this contract.

QUALIFYING QUESTIONNAIRE AND CONFIDENTIAL FINANCIAL STATEMENT: If requested by the Town, bidder under consideration for award shall furnish a qualifying questionnaire and a confidential certified financial statement, current within the past thirty days, which must be a complete report of the financial resources and liabilities, equipment available, past performance record, personnel and organization experience.

QUALIFICATION OF BIDDER: The project includes an Interlocal Agreement with the South Broward Drainage District (District) for improvements to their canals. Consequently, the bidder must demonstrate satisfactory evidence of experience with like work that is acceptable to the Town and the District. The contract will be awarded only to a responsible contractor qualified by this experience to do the work specified herein. The bidder shall submit, prior to award of contract, that he is fully prepared with the necessary organization, capital, equipment and machinery to complete the work to the satisfaction of the Town and the South Broward Drainage District within the time limit stated in the proposal.

The Town reserves the right to inspect the bidder's facilities, and to request such additional information which may be necessary to enable the Town to evaluate the bidder's ability to perform the work. Further, bids must be accompanied by evidence of appropriate licensure, and as may be required by Florida Statutes, Chapter 489 and other applicable laws, regulations, and ordinances to perform the work.

TOWN OF SOUTHWEST RANCHES, FLORIDA
"ALUMINUM SLUICE GATES" BID #: # 10-013

SUBCONTRACTOR AND SUPPLIERS: Bidder shall include in his Bid, the names and addresses of all subcontractors who will perform work representing a value of Ten (10) percent or more of the Contract Price. Bidders shall specify any intended subcontractors and demonstrate the subcontractor's qualifications to perform the designated scope of the work. This list shall be submitted with the intent that the Bidder shall employ these subcontractors for the trades noted.

DISQUALIFICATION OF BIDDER: No Bidder shall submit more than one Bid, and reasonable grounds for believing that a Bidder is interested in more than one Bid for the same work will cause rejection of all Bids in which such Bidder or Bidders are believed to be interested. Any or all Bids will be rejected if there is reason to believe that collusion exists among the Bidders. No participants in such collusions will be considered in future Bids for the same work.

RIGHT TO REJECT BID: The Town reserves the right to waive any informality and to reject any or all bids. Without limiting the generality of foregoing, any bid which is incomplete, obscure or irregular may be rejected. The Town intends to make an award to the bidder which is determined to be the lowest responsible and responsive bidder whose bid meets the requirements set forth in this Invitation for Bid, and in accordance with the Town's Procurement Code.

AWARD OF CONTRACT: The award of the contract, if it is awarded, will be to only a responsible Contractor whose qualifications indicate the award will be to the best interest of the Town and whose bid shall comply with the requirements of these specifications. In no case will the award be made until all necessary investigations have been made into the responsibility of the bidder and the Town is satisfied that the bidder is qualified to do the work and have the necessary organization, capital and equipment to carry out the provisions of the contract to the satisfaction of the Town within the time specified. Said qualifications shall enable the awarding authority of the Town to take into consideration the financial responsibility of the bidder, proven skill and expertise, facilities for performing the contract, and other such abilities of the bidder that include like work and experience that is acceptable to the Town and the South Broward Drainage District.

EXECUTION OF CONTRACT: Immediately following the award of the contract to the bidder by the Town, the attorney for the Town will prepare a formal contract to be executed by the parties.

FAILURE TO EXECUTE THE CONTRACT: The failure on the part of the successful bidder to execute the contract as required within 5 days will be just cause for the annulment of the award.

TOWN OF SOUTHWEST RANCHES, FLORIDA
"ALUMINUM SLUICE GATES" BID #: # 10-013

OMISSIONS, DISCREPANCIES; INTERPRETATIONS AND ADDENDUM: If a bidder desires that the Engineer interpret or clarify any part or parts of the plans and/or specifications, he will request in writing the Town to provide the same. The Town will, with reasonable promptness, issue such written clarification or interpretation in the form of an addendum, letter, or facsimile.

Should a Bidder find discrepancies in, or omissions from, the Drawings, Specifications or Contract Documents, he should at once notify the Deputy Town Clerk of Southwest Ranches. No oral interpretations shall be made to any bidder as to the meaning of any of the Contract Documents, Specifications or Plans, or be effective to modify any of the provisions of the Contract Documents.

All responses to questions or requests for clarification will be sent to prospective proposers, which have notified the Town of an interest in the project, by email, facsimile, or other means, and in the form of an addendum if deemed necessary by the Town. It is the responsibility of the interested firms to verify whether there are any addendums to this Invitation for Bid prior to submission of responses in accordance herewith.

Respondents are hereby notified that they shall not rely upon oral representations or discussions with the Town, including its staff or consultants. Only those communications issued by the Town, and which are in writing, may be considered as duly authorized expression. Also, only communications from responders that are signed, in writing, and timely submitted, will be recognized by the TOWN as duly authorized expressions on behalf of the respondent. Requests for clarification or additional information should be submitted to the Deputy Town Clerk in writing.

BID MODIFICATIONS: Bid modifications will be received from the bidder. Modifications must be in written or printed form and must be submitted five (5) calendar days prior to the date of the bid opening.

AMENDMENTS TO INVITATION FOR BID: The right is reserved as the interest of the Town may require, revising or amending the specifications and/or drawings prior to receipt of the proposal.

PUBLIC ENTITY CRIMES: Pursuant to 287.133(3)(a) Florida Statutes, no person or affiliate who has been placed on the convicted vendor list following a conviction for a public entity crime may submit a bid nor may be awarded or perform work as a contractor, supplier, subcontractor, or consultant for a period of 36 months from the date of being placed on the convicted vendor list.

LUMP SUM CONTRACT: This is a not to exceed lump sum contract. Unit prices shall be utilized only in calculating the cost of changes to the design, if any. In the event of any discrepancy between the bidder's unit pricing and the total not to exceed lump sum amount, the total lump sum shall control.

INDEMNIFICATION

1. **GENERAL INDEMNIFICATION:** The successful bidder shall be required to indemnify and hold harmless the Town, its officers and employees, from liabilities, damages, losses and costs, including but not limited to, reasonable attorney's fees, to the extent caused by the negligence, recklessness, or intentional wrongful misconduct of the successful bidder and persons employed or utilized by the bidder and persons employed or utilized by the bidder in the performance of the construction.

TOWN OF SOUTHWEST RANCHES, FLORIDA
"ALUMINUM SLUICE GATES" BID #: # 10-013

BID PROPOSAL FORM

Re: Fabrication of Aluminum Sluice Gates

The item descriptions are provided for the limited purposes set forth in this IFB and may not include all items and materials needed to complete the work.

In the event of any discrepancy between the bidder's unit pricing and the total not to exceed lump sum amount, the total lump sum shall control.

The undersigned hereby declares that he has examined the Contract Documents and fully familiarized himself with the said Documents and also any Local, State, County, and Federal laws pertaining to this project.

The undersigned, as Bidder, hereby declares that the only person or persons interested in the bid as Principal or Principals is or are named herein and that no other person than herein mentioned has any interest in this Bid or in the Agreement to be entered into; that this Bid is made without connection with any other person, company or parties making a bid or proposal; and that it is in all respects fair and in good faith without collusion or fraud.

The Bidder shall furnish prices for all bid items. Failure to do so may render the Bid invalid and cause its rejection.

The undersigned hereby proposes to furnish all labor, equipment and materials necessary to complete the work in strict accordance with the Contract Documents, schedules and plans, and all addendums, if issued, for the prices shown on the next page.

**TOWN OF SOUTHWEST RANCHES, FLORIDA
"ALUMINUM SLUICE GATES" BID #: # 10-013**

ITEM NO.	ITEM DESCRIPTION	UNIT	QTY	UNIT/ PRICE	TOTAL
1	Golden Gates GH-27 Aluminum Gate, 60"x60", Self contained frame, minimum frame height, UHMW seats, neoprene seal, Type 304 SS Stem, UHMW stem guide bushings, yoke mounted pedestal, gear crank operator, clear butyrate stem cover with mylar strip indicator, stop nuts. Preset to allow future replacement of manual gear operator with electric motor operator.	EA	1		
2	Golden Gates GH-27 Aluminum Gate, 66"x66", Self contained frame, minimum frame height, UHMW seats, neoprene seal, Type 304 SS Stem, UHMW stem guide bushings, yoke mounted pedestal, gear crank operator, clear butyrate stem cover with mylar strip indicator, stop nuts. Preset to allow future replacement of manual gear operator with electric motor operator.	EA	2		
3	Golden Gates GH-27 Aluminum Gate, 84"x84" self contained frame, minimum frame height, UHMW seats, neoprene seal, Type 304 SS Stem, UHMW stem guide bushings, yoke mounted pedestal, gear crank operator, clear butyrate stem cover with mylar strip indicator, stop nuts. Preset to allow future replacement of manual gear operator with electric motor operator.	EA	1		
4	Prices delivered to South Broward Drainage District. Prices to include SS anchor bolts.	Total	1		
	GRAND TOTAL BID PRICE				

All applicable federal, state and local taxes are included in the Bid Price. In the event of any discrepancy in the line item amounts, it is the total lump sum price which shall control.

TOWN OF SOUTHWEST RANCHES, FLORIDA
"ALUMINUM SLUICE GATES" BID #: # 10-013

Both the Bidder and the licensee shall fill in the information below, pursuant to Chapter 489, Florida Statutes. Licensee is defined as the person who is the licensed Contractor who qualifies the Bidding Company, Corporation or Partnership. If the Bidder is an individual, he must be licensed. (Please print or type, excluding signatures).

NAME: _____

ADDRESS: _____

FEIN: _____

LICENSE NUMBER: _____

STATE OR COUNTY: _____

LICENSE TYPE: _____
(Attach copy of license)

LICENSE LIMITATIONS, IF ANY: N/A
(Attach a separate sheet, if necessary)

LICENSEE SIGNATURE: _____

LICENSEE NAME: _____

BIDDER'S SIGNATURE: _____

BIDDER'S NAME: _____

BIDDER'S ADDRESS: _____

BIDDER'S PHONE NUMBER: Office: _____ Cell: _____

ADDENDUM ACKNOWLEDGMENT (if necessary):

The Bidder has received Addendum No _____ dated _____.

The Bidder has received Addendum No _____ dated _____.

The Bidder has received Addendum No _____ dated _____.

The Bidder has received Addendum No _____ dated _____.

TOWN OF SOUTHWEST RANCHES, FLORIDA
"ALUMINUM SLUICE GATES" BID #: # 10-013

By: _____
Name of Corporation

Address of Corporation

Signature of President

By: _____
President

(If the Bidder is a Corporation, affix corporate seal)

GOLDEN GATES MODEL GH-27

MD GH-27 ALUMINUM SLUICE GATE (FOR SQUARE OR RECTANGULAR OPENINGS)

GATE SHOWN FLATBACK & THIMBLE MOUNTED, SELF-CONTAINED WITH SIDE AND TOP WEDGING SYSTEM

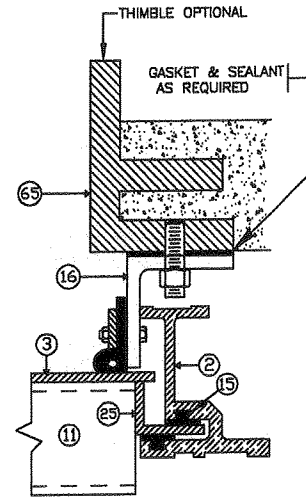
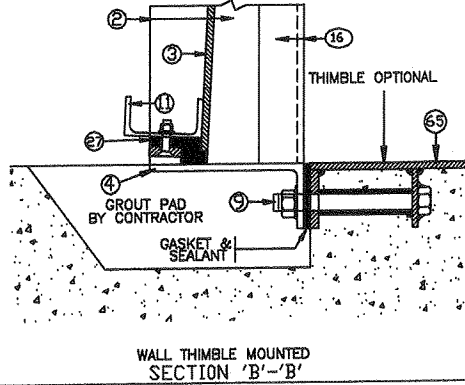
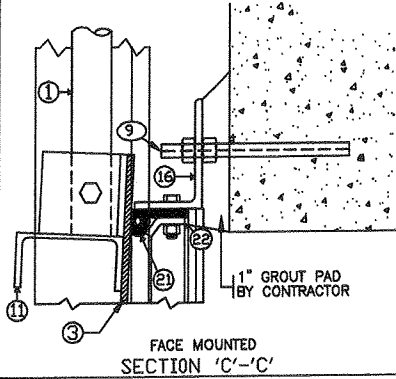

WALL THIMBLE MOUNTED SECTION 'A'-'A'

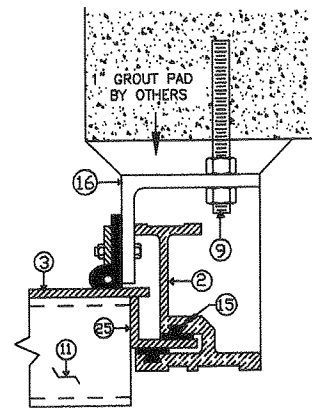

FLATBACK MOUNTED SECTION 'A'-'A'

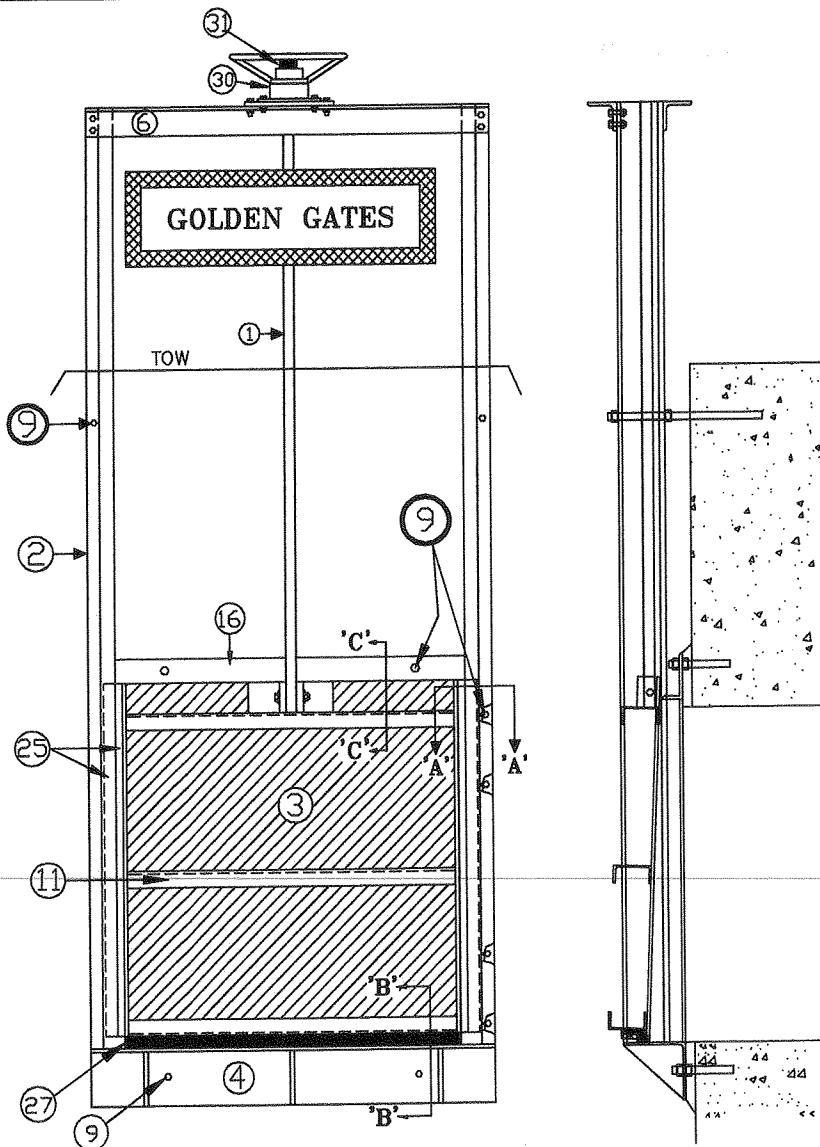

MD GH-27 AL. SLUICE GATE PARTS LIST

1	STEM
2	FRAME GUIDE
3	GATE HEAD
4	INVERT MEMBER
6	YOKE
9	GUIDE ANCHOR BOLTS\STUDS
11	STIFFENER
15	GUIDE ANGLE BEARING BAR, UHMW
16	SPIGOT
25	HEAD GUIDE MEMBER
27	INVERT SEAL, NEOPRENE RUBBER
30	OPERATOR
31	STOP NUTS
65	WALL THIMBLE
158	TOP WEDGES

**GOLDEN GATES MODEL GH-25 (FOR ROUND OPENINGS)
GH-27 ALUMINUM SLUICE GATE (FOR SQUARE OR RECTANGULAR OPENINGS)
30' SEATING 20' UNSEATING
SPECIFICATIONS**

- A. **SLUICE GATES:**
SLUICE GATES SHALL BE FROM ONE MANUFACTURER WITH SIMILAR SIZES IDENTICAL AND PARTS INTERCHANGEABLE. GATES SHALL BE MANUFACTURED BY GOLDEN HARVEST, INC., GOLDEN GATES TM (1-800-338-6238,) OR PRE-APPROVED EQUAL.
- B. **GUIDE FRAMES:**
SLUICE GATE GUIDE FRAMES SHALL BE EXTRUDED ALUMINUM WEIGHING NOT LESS THEN 4-1/4 POUNDS PER FOOT. THE GUIDE GROOVES IN WHICH THE HEAD GUIDE ANGLE TRAVELS SHALL CONTAIN ULTRA HIGH MOLECULAR WEIGHT POLYETHYLENE BEARING BARS IN DOVETAIL SLOTS.
- C. **SPIGOT:**
A ROLLED OR EXTRUDED ALUMINUM SPIGOT SHALL BE WELDED TO THE GUIDE FRAME. THE SPIGOT SHALL HAVE AN ANGLED SEATING SURFACE AND CONTAIN AN ADJUSTABLE RUBBER COMPRESSION SEAL. THE GATE SPIGOT OR BODY SHALL BE OF THE FLANGE BACK STYLE, WITH SQUARE, RECTANGULAR OR ROUND OPENING. THE FLANGE SHALL BE DESIGNED FOR MOUNTING TO A CONCRETE HEADWALL WITH STAINLESS STEEL ANCHOR BOLTS, OR ATTACHING TO A WALL THIMBLE WITH DOUBLE ENDED STAINLESS STEEL STUDS.
- D. **SLIDE:**
GATE SLIDE SHALL BE ALUMINUM PLATE ADEQUATELY REINFORCED FOR THE HEAD REQUIREMENTS SPECIFIED. THE HEAD GUIDE ANGLES SHALL BE ATTACHED TO SLIDE IN SUCH A WAY TO PLACE THE SLIDE IN AN ANGLE CORRESPONDING TO THE SEATING SURFACE OF THE SPIGOT.
- E. **WEDGES:**
SLUICE GATES SHALL HAVE INTERMEDIATE WEDGES. WEDGES SHALL BE STAINLESS STEEL WITH ULTRA HIGH MOLECULAR WEIGHT POLYETHYLENE FACES AND BE FULLY ADJUSTABLE.
- F. **OPERATOR:**
MANUALLY OPERATED LIFTING MECHANISMS SHALL BE OF THE HAND WHEEL OR CRANK OPERATED FULLY ENCLOSED GEARED TYPE AS INDICATED ON THE DRAWINGS AND SCHEDULE. THE HAND WHEEL TYPE SHALL BE WITHOUT GEAR REDUCTION. THE CRANK OPERATED TYPE SHALL HAVE EITHER A SINGLE OR DOUBLE GEAR REDUCTION DEPENDING UPON THE LIFTING CAPACITY REQUIRED. OPERATOR HOUSING SHALL BE CAST STEEL OR CAST IRON. EACH TYPE SHALL BE FURNISHED WITH A THREADED BRONZE LIFT NUT TO ENGAGE THE THREADED PORTION OF THE STEM. THE LIFT NUT SHALL BE FLANGED AND SUPPORTED ON ROLLER BEARINGS TO TAKE THE THRUST DEVELOPED DURING OPENING AND CLOSING OF THE GATES. ANTI-FRICTION THRUST WASHERS OR BEARING PLATES WILL NOT BE PERMITTED. GEARS, WHERE REQUIRED, SHALL BE PROVIDED WITH MACHINE CUT TEETH DESIGNED FOR SMOOTH OPERATION. THE BEARINGS AND LIFT NUT SHALL BE MOUNTED IN A HOUSING, WHICH IN TURN SHALL BE SUPPORTED BY A PEDESTAL OR MOUNTED ON THE YOKE OF THE GATE. LUBRICATION FITTINGS SHALL BE PROVIDED IN THE GEAR HOUSING TO PERMIT LUBRICATION OF ALL GEARS AND BEARINGS. MECHANICAL SEALS SHALL BE PROVIDED AROUND LIFT NUT AND PINION SHAFT. OPERATORS SHALL BE PROVIDED WITH A VENTED CLEAR BUTYRATE STEM COVER HAVING A TRANSPARENT MYLAR SCALE CALIBRATED IN FEET AND INCHES TO SHOW GATE POSITION. ADJUSTABLE BRONZE STOP COLLARS SHALL BE PROVIDED TO LIMIT BOTH UPWARD AND DOWNWARD TRAVEL. THE DISTANCE BETWEEN THE HAND WHEEL AND THE OPERATING FLOOR SHALL BE APPROXIMATELY 36". AN ARROW SHALL BE CAST ON THE GEAR HOUSING OR THE HAND WHEEL TO INDICATE THE DIRECTION OF ROTATION TO OPEN THE GATE. A MAXIMUM EFFORT OF 40 POUNDS SHALL BE REQUIRED TO OPERATE THE GATE AFTER IT IS UNSEATED.
- G. **STEM:**
THE OPERATING STEM SHALL BE TYPE 304 OR 316 STAINLESS STEEL OF SUITABLE LENGTH AND AMPLE STRENGTH FOR THE INTENDED SERVICE. THE STEM DIAMETER SHALL BE CAPABLE OF WITHSTANDING TWICE THE RATED OUTPUT OF THE OPERATOR AT 40 POUNDS PULL AND SHALL BE SUPPORTED SUCH THAT THE L/R RATIO FOR THE UNSUPPORTED PART OF THE STEM DOES NOT EXCEED 200. THE THREADED PORTION OF THE STEM SHALL HAVE ACME TYPE COLD ROLLED THREADS WITH A MAXIMUM SURFACE ROUGHNESS OF 16 MICROINCHES. MACHINE CUT THREADS WILL NOT BE PERMITTED.
- H. **STEM GUIDES:**
STEM GUIDES (WHEN REQUIRED) SHALL BE SUPPLIED TO SUPPORT THE STEM. STEM GUIDES SHALL BE OF STAINLESS STEEL WITH ULTRA HIGH MOLECULAR WEIGHT POLYMER BUSHINGS HAVING A MINIMUM THICKNESS OF 3/4". BUSHINGS SHALL BE MACHINED TO A SIZE 1/16" OVER STEM DIAMETER. BUSHINGS SHALL BE ATTACHED TO SUPPORT MEMBER WITH STAINLESS STEEL BOLTS AND BE ADJUSTABLE IN TWO DIRECTIONS.

- I. WALL BRACKETS AND PEDESTALS:
WALL BRACKETS SHALL BE STAINLESS STEEL. PEDESTALS SHALL BE OF FABRICATED STEEL AND SHALL BE SHOP PAINTED AS SPECIFIED IN THE GENERAL EQUIPMENT STIPULATIONS.
- J. WALL THIMBLES:
WALL THIMBLES SHALL BE STAINLESS STEEL OR DUCTILE IRON, SUITABLE FOR MOUNTING THE SLUICE GATE AND OF THE SIZE AND TYPE SHOWN ON THE DRAWINGS.
- G. LEAKAGE:
LEAKAGE SHALL BE BELOW THAT ALLOWED BY AWWA C501 STANDARDS FOR SLUICE GATES, UP TO A MAXIMUM OF 20.0 FEET UNSEATING HEAD.

K. MATERIALS:

COMPONENTS	MATERIAL
SLIDE, SPIGOT, FRAME, STIFFENERS, YOKE, GUIDE ANGLES	ALUMINUM 6061-T-6 ASTM B-209, ASTM B-211
STEMS	STAINLESS STEEL TYPE 304 OR 316, ASTM A-276
FASTENERS AND ANCHOR BOLTS	STAINLESS STEEL TYPE 304 OR 316
SEAL	NEOPRENE ASTM D-2000
BEARING BARS	ULTRA HIGH MOLECULAR WEIGHT POLYETHYLENE ASTM D4020

TOWN OF SOUTHWEST RANCHES, FLORIDA
 "ALUMINUM SLUICE GATES" BID #: # 10-013

ITEM NO.	ITEM DESCRIPTION	UNIT	QTY	UNIT/PRICE	TOTAL
1	Golden Gates GH-27 Aluminum Gate, 60"x60", Self contained frame, minimum frame height, UHMW seats, neoprene seal, Type 304 SS Stem, UHMW stem guide bushings, yoke mounted pedestal, gear crank operator, clear butyrate stem cover with mylar strip indicator, stop nuts. Preset to allow future replacement of manual gear operator with electric motor operator.	EA	1	8,750 ⁻	8,750 ⁻
2	Golden Gates GH-27 Aluminum Gate, 66"x66", Self contained frame, minimum frame height, UHMW seats, neoprene seal, Type 304 SS Stem, UHMW stem guide bushings, yoke mounted pedestal, gear crank operator, clear butyrate stem cover with mylar strip indicator, stop nuts. Preset to allow future replacement of manual gear operator with electric motor operator.	EA	2	9,800 ⁻	19,600 ⁻
3	Golden Gates GH-27 Aluminum Gate, 84"x84" self contained frame, minimum frame height, UHMW seats, neoprene seal, Type 304 SS Stem, UHMW stem guide bushings, yoke mounted pedestal, gear crank operator, clear butyrate stem cover with mylar strip indicator, stop nuts. Preset to allow future replacement of manual gear operator with electric motor operator.	EA	1	16,450 ⁻	16,450 ⁻
4	Prices delivered to South Broward Drainage District. Prices to include SS anchor bolts.	Total	1		44,800 ⁻
	GRAND TOTAL BID PRICE				44,800.00

All applicable federal, state and local taxes are included in the Bid Price. In the event of any discrepancy in the line item amounts, it is the total lump sum price which shall control.

TOWN OF SOUTHWEST RANCHES, FLORIDA
"ALUMINUM SLUICE GATES" BID #: # 10-013

Both the Bidder and the licensee shall fill in the information below, pursuant to Chapter 489, Florida Statutes. Licensee is defined as the person who is the licensed Contractor who qualifies the Bidding Company, Corporation or Partnership. If the Bidder is an individual, he must be licensed. (Please print or type, excluding signatures).

NAME: GIRALT ENTERPRISES, FMC.

ADDRESS: 12260 SW 94 ST, MIAMI, FL 33186

FEIN: 65-0066382

LICENSE NUMBER: 203415-5

STATE OR COUNTY: MIAMI-DADE

LICENSE TYPE: OCCUPATIONAL
(Attach copy of license)

LICENSE LIMITATIONS, IF ANY: N/A
(Attach a separate sheet, if necessary)

LICENSEE SIGNATURE: _____

LICENSEE NAME: RENZO GIRALT

BIDDER'S SIGNATURE: _____

BIDDER'S NAME: GIRALT ENTERPRISES, FMC.

BIDDER'S ADDRESS: 12260 SW 94 ST, MIAMI, FL 33186

BIDDER'S PHONE NUMBER: Office: 305-4454 Cell: 305-915-8974

ADDENDUM ACKNOWLEDGMENT (if necessary): NONE

The Bidder has received Addendum No _____ dated _____.

The Bidder has received Addendum No _____ dated _____.

The Bidder has received Addendum No _____ dated _____.

The Bidder has received Addendum No _____ dated _____.

TOWN OF SOUTHWEST RANCHES, FLORIDA
"ALUMINUM SLUICE GATES" BID #: # 10-013

By: GIRALT ENTERPRISES, INC
Name of Corporation

12260 SW 94 ST
Miami, FL 33186
Address of Corporation



Signature of President

By: PEDRO GIRALT
President

(If the Bidder is a Corporation, affix corporate seal)

Town of Southwest Ranches
Preserving Our Rural Lifestyle

PURCHASE ORDER
2010

6589 SW 160 Avenue
 Southwest Ranches, FL 33331
 Phone 954 434 0008 Fax 954 434 1490

P.O. NUMBER: _____
 Assigned by accounting system

The P.O. number must appear on all related correspondence, shipping papers, and invoices:

The P.O. is subject to the attached Terms and Conditions.

To:

Ship To:

Town of Southwest Ranches
 6589 SW 160th Avenue
 Southwest Ranches, FL 33331

P.O. DATE	REQUISITIONER	SHIPPED VIA	F.O.B. POINT	TERMS

QTY	UNIT	ACCT. Num.	DESCRIPTION	UNIT PRICE	TOTAL
				SUBTOTAL	\$
				TOTAL	\$

 Approved by Department Head Date

 Authorized by Finance Administrator Date

 Authorized by Town Administrator Date

Accepted by:

 Date

Terms and Conditions

1. The item descriptions are provided for the limited purposes set forth in this IFB and may not include all items and materials needed to complete the work. The Contractor hereby proposes to furnish all labor, equipment and materials necessary to complete the work in strict accordance with the schedules and plans, and all addendums, if issued, for the prices shown on this Purchase Order.

The scope of services includes fabrication of six (6) aluminum sluice gates Model Golden GH-27 in accordance with the plans and specifications provided in the Invitation For Bid. The price shall include delivery of one 60"x60" gate, one 84"x84" gate and two 66"x66" gates to the South Broward Drainage District. Prices also include SS anchor bolts and associated hardware related to self-contained frame, minimum frame height, UHMW seats, neoprene seal, Type 304 SS Stem, UHMW stem guide bushings, yoke mounted pedestal, gear crank operator, clear butyrate stem cover with mylar strip indicator, and stop nuts. The gates will also be preset to allow for future replacement of manual gear operator with electric motor operator.

2. The Town is exempt from Florida Sales and Federal Excise taxes on direct purchase of tangible property.
3. This is a not-to-exceed lump-sum contract.
4. The bidder is required to familiarize himself with the nature and extent of the work and any local conditions that may in any manner affect the work to be done and the equipment, materials and labor required. He is also required to examine carefully the plans, specifications and to inform himself thoroughly regarding any and all conditions and requirements that may in any manner affect the work to be performed under this Purchase Order.
5. Vendor, by accepting this order, assumes complete responsibility for any alleged patent infringements, and will save the Town harmless from all suits and payments.
6. The Contractor shall be required to indemnify and hold harmless the Town, its officers and employees, from liabilities, damages, losses and costs, including but not limited to, reasonable attorney's fees, to the extent caused by the negligence, recklessness, or intentional wrongful misconduct of the successful bidder and persons employed or utilized by the bidder and persons employed or utilized by the bidder in the performance of the work.
7. The Contractor shall procure all required permits and arrange for inspections and pay such fees as are thereby incurred. Any alternatives proposed by the Contractor must be in compliance with the permit requirements. The South Broward Drainage District will supervise any requests for needed modifications to the permits.